

DIGITAL AND FREE - THE NEW MONTHLY MAGAZINE FROM KSP REPORTAGES

NEWS | KSP GRAND | REPORTS | INTERVIEW | INTERNATIONAL | NATIONAL | PRODUCTS | AUTOSPORT | VIDEO

# KARTCOM

ONLINE KARTING DOCUMENT

NEWS #3

## FFSA

FIRST FFSA CUPS  
WINNERS AND CHAMPIONS  
IN FRANCE

## BATTLES ON TRACK

AT CASTELLETTO  
IN THE ROTAX EURO CHALLENGE

## INTERVIEW

REVIEW OF THE WSK KARTING SEASON  
WITH LUCA DE DONNO

CIK EURO KF AND KFJ ALREADY HALFWAY THROUGH



# #3 SUMMARY

## 004 EDITORIAL

### 007 NEWS

- KZ 125 club racing at Laval
- EFK National Assembly
- The fun of simulation at Le Mans
- Control tyres and fuel successful at Le Mans
- Milane Pételet
- Raucci in F3 in Brazil
- Already on the podium in Indy Lights for Baron
- Coppa dei Campioni
- CIK • A new fairing fixing
- WSK Promotion always leading with TV coverage
- The death of Michel Fabre
- Calendar of upcoming races

## 031 KSP GRAND

### 033 REPORTS

- Senna Memorial a success despite the rain!

### 037 INTERVIEW

- Interview with Luca De Donno

## 041 INTERNATIONAL

- La Conca • European KF & KFJ Championship
- Zuera • European KF & KFJ Championship
- Castelletto • Rotax Euro Challenge

## 081 NATIONAL

- Le Mans • French Cup for KZ125 & Gentleman
- Ledenon • French Superkart Championship
- Varennes / Allier • Launch of NSK 2014
- Ostricourt • FFSA French Championship

## 125 PRODUCTS

- Alpha Karting
- Action Karting
- ITAKA

## 127 CIRCUITS

- Genk
- Salbris
- Le Mans

## 133 CARS

- F4: Boccolacci rules at Pau
- FR 2.0: Alexander Albon
- "I know I've done good work"

## 145 VIDEO

- Alex Baron Indy Lights (Long Beach 2014)
- Reportage L'EQUIPE TV
- Superkart à Hockenheim • Henrick Lilja • PVP-PVP
- European Championship 2014 La Conca • finale KF
- European Championship 2014
- La Conca • finale KFJ

## 025 WSK PROMOTION ALWAYS LEADING WITH TV COVERAGE



# 059

ZUERA  
EUROPEAN  
CHAMPIONSHIP  
KF & KFJ

## 081 LE MANS FRENCH CUP FOR KZ125 & GENTLEMAN



# 141

FR 2.0:  
ALEXANDER  
ALBON



ALEX BARON  
INDY LIGHTS

# 145

THE FUN OF  
SIMULATION  
AT LE MANS

# 009



# 037

INTERVIEW WITH  
LUCA DE DONNO



# 069

CASTELLETTO  
ROTAX EURO  
CHALLENGE

VARENNES  
LAUNCH OF  
NSK 2014

# 095





# THE 2014 RACING SEASON IS IN FULL SWING



Since May, both national and international karting has entered the busiest three months before the August break. The CIK-FIA European KF and KF-Junior Championships are already half way through, as is the Rotax Euro Challenge. In France, the first two French Championships have already been awarded.

The quality and intensity of racing causes us to forget for a moment the economic difficulties that impede the development of competition karting, despite the always lively attractions of the sport. The organisers are making

efforts to ensure better media coverage, particularly with Live TV on the internet that has quickly spread, but broadcasting on conventional channels remains the exception.

Kartcom News has now got into its stride and the success is confirmed, particularly internationally with a strong increase in readers for the English version. The launch of the new digital magazine and free KSP reports have somewhat shaken the media landscape in karting, causing reactions from other media for the greater good of the discipline.

## IN EARLY JULY KARTCOM NEWS NUMBER 4 WILL BE RELEASED

with the start of the CIK-FIA European KZ and KZ2 Championship and Academy Trophy, the third round of the European KF Championship, the French Superkart Championship and two rounds of NSK. At the same time, the Italian F4 Championship will have completed the first two events.

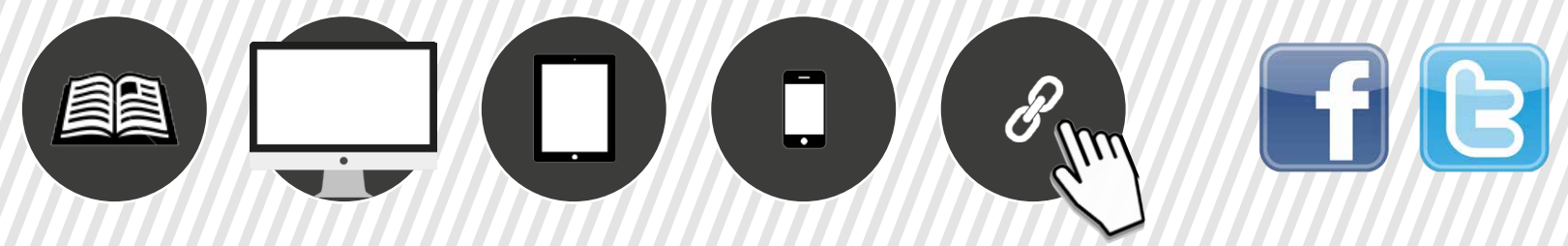

<p><b>KARTCOM NEWS #3</b> Communication Document Created by the company KSP Reportages 13 avenue Eugène Pelletan 94400 Vitry-sur-Seine - France +33 1 46 82 60 12 +33 6 08 26 61 11 office@kartcom-news.com</p>	<p><b>PUBLICATION MANAGER</b> Philippe Kalmès <b>EDITOR IN CHIEF</b> Frédéric Billet <b>ARTISTIC DIRECTOR</b> Céline Quiros <b>PHOTOGRAPHER</b> Guillaume Veuve • Chris Walker • Philippe Kalmès</p>	<p><b>TRANSLATION</b> Mary-Ann Horley <b>ADMINISTRATION</b> Cristina Kalmès, Annie Dujols <b>NEWS &amp; RELEASES</b> Service presse FFSA • CIK-FIA • Prodiff • Kartcom • Renault Sport</p>	<p><b>PHOTOGRAPHS</b> KSP Photo Agency ( Guillaume Veuve &amp; Philippe Kalmès ) • DPPI • Renault Sport • Kart'im <b>DISTRIBUTION</b> Free This digital document was distributed to 16,000 people</p>	<p><b>CIK-FIA KARTING AWARDS</b> The KSP agency has been recognised for the CIK-FIA «BEST PHOTOGRAPH» of 2007 • 2008 • 2011 • 2012 and 2013. <b>STARS &amp; CRAFTS 2012</b> Departmental prize (94) «Dynamic Business»</p>
---	--	--	---	--

TOUTE REPRODUCTION TOTALE OU PARTIELLE EST STRICTEMENT INTERDITE SANS AUTORISATION PRÉALABLE FAITE AUPRÈS DE LA SOCIÉTÉ KSP REPORTAGES



# Sodi

PASSION FOR INNOVATION

SODIKART.COM





Info FFSA / © Photo KSP - Philippe Kalmès

# CLUB KZ 125 RACE AT LAVAL

AT THE INTERNATIONAL HISTORIC KART ASSEMBLY WHICH TAKES PLACE ON JUNE 7TH AND 8TH AT THE LAVAL CIRCUIT, A KZ 125 RACE HAS BEEN ORGANISED TO DEMONSTRATE THE EVOLUTION OF KARTING TO THE SPECTATORS.

**A**SK Laval will run this competition on Sunday, June 8th, 2014 and will award € 8,000 worth of prizes. The first will win € 3,000, the second € 2,000 and the third € 1,000. The remaining € 2,000 will be awarded in a raffle. The entry fee is € 100 including free practice.

Please note, places are limited to 36 drivers!  
Send entries to Didier Turpin at 83 rue d'Avesnières 53000 LAVAL using the entry form downloadable below.

KARTING-LAVAL.FR



Info FFSA / © Photo KSP - Philippe Kalmès

# EFK NATIONAL ASSEMBLY: EVERYONE AT LE CASTELLET ON OCTOBER 29TH

THE DATE FOR THE THIRD NATIONAL ASSEMBLY HAS BEEN FINALISED. 38 STUDENTS AND SUPERVISORS FROM THE EFK WILL MEET ON WEDNESDAY, OCTOBER 29TH, 2014 AT LE CASTELLET (83)

FFSA-EFK.COM

## INTERNET : THE NEW EFK SITE IS BEING FINALISED

The national EFK network will soon have a new website. The FFSA and its partners are currently working on the ergonomics and presentation of this essential promotion and communication tool, and it will be open at [www.ffsa-efk.com](http://www.ffsa-efk.com) before the start of the summer holidays.

## EFK ANCENIS IS OPEN!

EFK Ancenis opened its doors on March 19th. Students at this new facility, where classes are held every other Wednesday under the leadership of Pierre Lemarié (a qualified instructor), will also benefit from the facilities at the Roger Gaillard circuit. There have also been some improvements from the ASK Ancenis team chaired by Stéphane Grevet, including in recent weeks a brand new stand with a capacity of 500 spectators!

## STUDENTS AT EFK HAINAUT HONOURED

Congratulations to the students at EFK Hainaut for their results obtained during the friendly race at Abbeville, held in March. Most specifically to Andrea (the winner), Steven (second and with the fastest lap) Théau (third) Sumiyya (fourth), Antoine (sixth) and finally Meline who finished his first race in seventh position.





By Frederic Billet / © Photo KSP - Philippe Kalmès

# FUN WITH SIMULATION AT LE MANS

LEMANS-KARTING.COM

THE TWENTY FOUR, THE BEAUTIFUL NEW BUILDING AT THE NEW LE MANS KARTING INTERNATIONAL CIRCUIT, HAS RECENTLY OPENED A ROOM DEDICATED TO DRIVING SIMULATORS WHICH COMPLEMENTS ITS RECEPTION FACILITIES AND CATERING.

Located on fifteen sites in France and in Europe, the Ellip6 system equips the Le Mans site with six simulators with the major feature of moving on 6 axes. A gamer with international titles, Christophe Bailly - aka Dolphins - showed us some of the extended capabilities of these machines. More than 50 channels are available with twenty cars, whose behaviour was modeled in collaboration with real drivers and engineers. F1, LMP1, GT, Rally, Touring Cars, the choice is vast, especially as the cars have several types of adjustment at different tracks.

The benefits are personalised sessions in addition to basic sessions from €10. You can easily organise a challenge with several drivers by choosing the duration of free practice, qualifying and the race. Dolphins' dream would be to organise a real 24 Hours of Le Mans, virtually. A few steps from the real 24 Hour circuit, it would certainly be attractive!

Focused on the pleasure of driving and racing against opponents, the Ellip6 experience is very convincing. Realism is important and thrills are guaranteed in the simulators. Beyond simple gaming, Ellip6 offers excellent training for drivers as stated by Olivier Panis: "It is a magical tool, both for training and for fun!"





By Frederic Billet / © Photo KSP - Philippe Kalmès

# FFSA : TYRE AND FUEL CONTROLS SUCCESSFUL AT LE MANS

THE FRENCH KZ 125 CUP AT LE MANS INAUGURATED THE NEW TYRE CONTROL PROCEDURES WITHOUT PARC FERME, IN ADDITION TO CONTROL FUEL FROM A NEARBY PETROL STATION. THOSE RESPONSIBLE FOR THE TECHNICAL CHECKS, PATRICK BAUSOLA AND JEAN-PIERRE BAUDRY, WERE VERY SATISFIED WITH THE OUTCOME OF THE COMPETITION.

**||** *We did a lot of prevention during free practice and briefing so 100% of tyres have been checked with the MiniRAE Lite! There were no problems in connection with reading the barcode on the tyres, and everything went very well. Arguably no one missed parc fermé! It's easier this way and it saves time. We also controlled fuel for all competitors. We were able to verify 47 tanks, or about half of the grid, which is not bad at all!"*

FFSAKARTING.ORG

**FFSA**







By Frederic Billet / © Photo KSP - Philippe Kalmès

# STRONG AMBITIONS FOR MILANE PÉTELET IN MINIME WITH ALPHA

FOR HIS THIRD SEASON IN THE MINIME CATEGORY, MILAN PÉTELET IS THE TOP OF THE TABLE AT THE WHEEL OF HIS NEW ALPHA CHASSIS. AFTER TWO VICTORIES AT ARVILLERS AND SOUCY, HE LEADS THE STANDINGS OF THE REGIONAL CHAMPIONSHIPS IN ILE-DE-FRANCE, AND ALSO OF THE NEW STARS OF KARTING SERIES.



Since starting in 2011 in the Minikart category, Milane has progressed considerably. It must be said that he lives in a family who are passionate about competition. Before karting, Milane raced in motocross, but he decided to change over after a bad fall on two wheels. Although he was only 29th in the French Minime Championship in 2012, he was 6th in the national competition in 2013 after taking the second step of the podium at Angerville.

2014 promises to be a particularly important year for Milane Pételet, who is determined to complete this step before continuing his career in higher classes and later in car formulae. The experienced Freddy Martins is now working exclusively with Milane with the mission to win the French Championship which starts at the end of May with a race at Ostricourt.



# RAUCCI IN F3 IN BRAZIL

GIULIANO RAUCCI HAS ACHIEVED PROMISING PERFORMANCES SINCE THE BEGINNING OF THE SEASON IN KF-JUNIOR, ESPECIALLY HIS MEMORABLE POLE POSITION AT THE WSK SUPER MASTER SERIES AT SARNO. HE WAS SCHEDULED TO CONTINUE UNTIL THE END OF THE YEAR IN KARTING IN EUROPE BEFORE MOVING TO CARS WITH TESTING AFTER THE WORLDS, THEN RACING IN 2015.

**A** new situation has recently caused a change. At 15 years old, Giuliano took the opportunity to start racing now in F3 with the team his father owns in Brazil, the RR Racing Team, along with several drivers of the same age. The choice was made by the young driver who was able to convince his father with solid arguments, and the Raucci family made the decision with great emotion.

Determined to move forward, Giuliano recognises easily that he learned a lot in European karting which is an irreplaceable learning experience, thanks to Ennio Gandolfi who trained and actively supported him. He has not completely turned his back on karting as he will continue to race in the main Brazilian championships in addition to his testing at the wheel of a Dallara F309 this year

before going full time into car racing in 2015. The choice has not yet been made so far between Brazilian F3, Eurocup Formula Renault and F4.







# NSK

National Series Karting  
**2014**

**LA SÉRIE N°1 EN FRANCE**  
**AVEC PLUS DE 200 PILOTES PAR MEETING !\***

\*213 PILOTES / MEETING SUR L'ENSEMBLE DE L'ANNÉE 2013

## DATES & CIRCUITS 2014

- NSK 1 : VARENNES S/ ALLIER - 16/18 MAI 2014
- NSK 2 : SALBRIS - 6/8 JUIN 2014
- NSK 3 : LE MANS - 27/29 JUIN 2014
- NSK 4 : ESSAY - 22/24 AOÛT 2014

INSCRIPTIONS & INFOS SUR [ns-karting.com](http://ns-karting.com)

## CATÉGORIES

- ROTAX MAX
- X30 SENIOR
- ROTAX MAX MASTER
- ROTAX DD2/DD2 MASTER
- NATIONALE 150/160
- KRA 7-11
- KRA 11-15



Une organisation :



By Frederic Billet / © Photo DR

# A PODIUM ALREADY IN INDY LIGHTS FOR ALEX BARON

ALEX BARON IS BRILLIANTLY CONTINUING HIS AMERICAN APPRENTICESHIP IN INDY LIGHTS. HE TOOK HIS FIRST PODIUM WITH A SECOND PLACE BEHIND HIS TEAMMATE, THE EXPERIENCED GABBY CHAVES (THE 2013 VICE-CHAMPION), AT BARBER MOTORSPORTS PARK, AFTER ONLY FOUR RACES IN THE CATEGORY.

**H**e is 5th overall with the aim of quickly taking his first victory in Indy Lights. This weekend Alex has just completed his debut on the famous Indianapolis oval in the rookie tests, a necessary step before they jump behind the wheel of racing cars that run at 330 km / h average!

L'Equipe TV went over to do a story on him during the race in Long Beach, which will be out in a few weeks.



FOLLOW THE AMERICAN ADVENTURES OF ALEX BARON ON 13TH AVENUE'S FACEBOOK PAGE.



# COPPA DEI CAMPIONI THE TRADITION LIVES ON!

THE ORIGINAL COPPA DEI CAMPIONI BECAME A TRADITION IN THE PREVIOUS CENTURY, AND THE CURRENT VERSION FOR HISTORIC KARTS IS FOLLOWING IN ITS FOOTSTEPS. ON THE WEEKEND OF 18 MAY, THE THIRD EDITION OF THE EVENT TOOK PLACE AT THE PISTA AZZURRA IN JESOLO (ITALY), A CIRCUIT ITSELF STEEPED IN HISTORY.

More than 120 enthusiasts from six different nations demonstrated their historic equipment, with the oldest (1959), and we mean the chassis not the driver, dating back to the pioneer days of karting. Organised by the Automotoclub Storico Italiano in accordance with the CIK guidelines for Historic karts, the event was filled with passion, fun and friendship from early morning to late into the night, both on and off the track. It was fantastic to see not only top karters from the past but also those

responsible for the design of ground-breaking equipment or famous engine tuners exchanging stories from days gone by.

After the prize-giving ceremony and words of thanks spoken to those behind the excellent promotion of the heritage of karting, everybody went home satisfied in the knowledge that in twelve months, another episode would be added to the tradition of the Coppa dei Campioni.





# A NEW FRONT FAIRING ATTACHMENT TO FIGHT AGAINST ON-TRACK INCIDENTS

THE CIK-FIA ANNOUNCED IN LATE 2014 THAT IT WOULD WORK TO MAKE RACING FAIRER BY FIGHTING AGAINST BAD BEHAVIOUR ON THE TRACK. ONE OF THE WAYS CHOSEN FOR THIS WILL BE IN USE IN 2015, A NEW SYSTEM FOR FIXING THE FRONT FAIRING TO LIMIT CONTACT BETWEEN KARTS.

Since the introduction of kart bodywork, especially the rear bumper, the behaviour of some drivers who are accustomed to pushing other competitors has become unacceptable. Karting too often looks like stock car racing. Frustrated by the lack of action by the various parties involved, the CIK put together a small group of experts to find a solution. The CIK then asked the company KG to translate the ideas into reality. It soon became clear that no viable solution could be found using the rear bumper, so research was directed towards the front of the kart. KG submitted a proposal to create a special "front fairing mounting kit".

Attempts on the track, a satisfactory solution has been found. With this new fixing, if a driver pushes the driver directly in front of him with a force considered greater than what can be tolerated, a difference of more than 5 km / h, the front fairing will come out of its initial position and will be shifted to the ground while remaining secured to the chassis. The offending driver will then go through the Repair Area to reposition the front fairing properly. The operation is quick and simple, but very detrimental to the driver's classification, prompting reflection and eventually causing a real change in behaviour on the track.

The World Motor Sport Council has already approved the new direction of the

CIK-FIA. The technical regulation and the procedure for the approval of bodywork is ready to implement the new fixing from 1st January 2015 in the CIK-FIA competitions. The ASNs can also apply this new rule.

A sufficiently stringent approval process will ensure perfect similarity between all models, which will respond to impact in the same way. The tests this year in collaboration with several manufacturers have left no room for doubt on this point, as several models have already met these strict criteria.

After several more and more successful

SEE MORE +

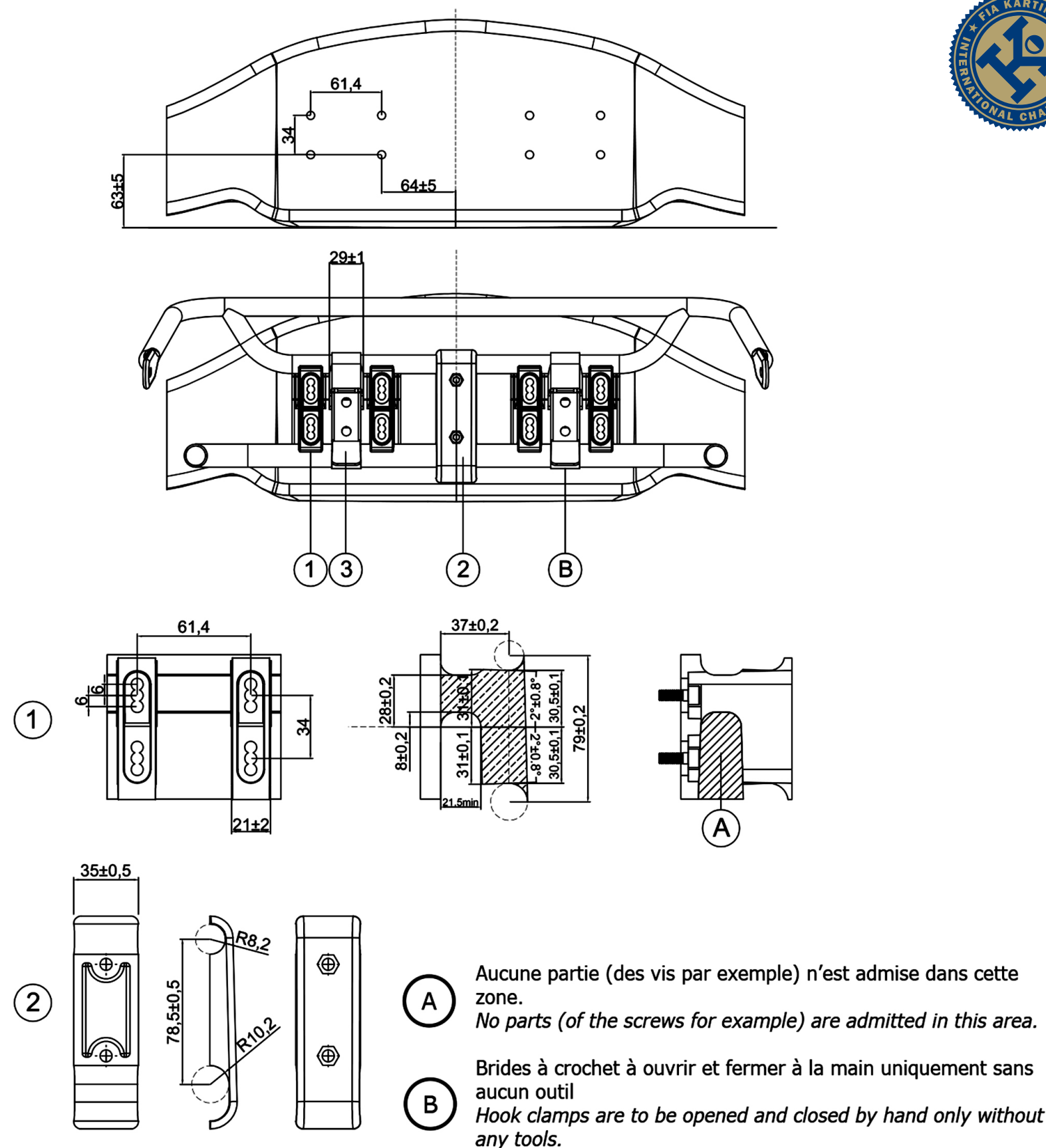





By Frederic Billet / © Photo KSP - Philippe Kalmès

# WSK PROMOTION ALWAYS AT THE FOREFRONT OF THE TV LIVE BROADCAST

LIVE BROADCASTING ON INTERNET TV IS NOW ALMOST INEVITABLE AT MAJOR KARTING EVENTS.

Filming equipment and production possibilities are now much more affordable, but live TV quality is not within the reach of anyone ... consistency and serious skills are the key to success.

A pioneer of live TV, WSK Promotion has improved its performance in 2014 by investing in new equipment, particularly in terms of organisation, now well established alongside race control in a dedicated video truck. This facility also covers international CIK-FIA events with

a simulcast on both the [www.cikfia.tv](http://www.cikfia.tv) and [www.cikfiachampionship.com](http://www.cikfiachampionship.com) sites.

[WWW.CIKFIA.TV](http://WWW.CIKFIA.TV)

[WWW.CIKFIACHAMPIONSHIP.COM](http://WWW.CIKFIACHAMPIONSHIP.COM)





Info CIK / © Photo DR

# DEATH OF MICHEL FABRE

THE ANNOUNCEMENT OF THE DEATH, ON THURSDAY, MAY 15, 2014, OF THE FRENCHMAN MICHEL FABRE HAS CAUSED GREAT SADNESS IN THE HEART OF KARTING. HE WAS AN IMPORTANT FIGURE IN THE HISTORY OF MOTORSPORT AND ILLNESS PREVAILED AT THE AGE OF 76.

**M**ichel Fabre was one of the pioneers of karting in the 60s. An ex-driver with glowing track record in national and international competition, Michel was part of the French team under the responsibility of Jean-Marie Balestre. A recognized professional, he imported Tecno chassis and IAME engines into France as Sovame with Andrée, his wife. He was also the

manufacturer of the Squalo and Python chassis, which helped many drivers to victory including Alain Prost.

As an official, Michel Fabre fulfilled several important functions, from the Vice-Presidency of the FdK (Karting Federation) to the first chair of the FFSA National Karting Commission through its

involvement in the development of 250cc Superkart in France. He was also a starter at many CIK-FIA Competitions.

He participated in the manufacture of cars, at the start of Formula Renault and in the 70s the French team in F3 and F2, Tecno Motul, with drivers such as Jean-Pierre Jausaud and François Cevert.





<p><b>08.06.14</b></p> <p><b>SALBRIS</b> NSK</p> <ul style="list-style-type: none"> <li>* NATIONALE 150 &amp; 160</li> <li>* KRA 7 &amp; 11 * X30</li> <li>* DD2 &amp; DD2 MASTER</li> <li>* ROTAX MASTER * ROTAX MAX</li> </ul>	<p><b>15.06.14</b></p> <p><b>GENK</b> ACADEMY TROPHY &amp; EUROPEAN CHAMPIONSHIP</p> <ul style="list-style-type: none"> <li>* KF</li> <li>* KZ</li> <li>* KZ2</li> </ul>	<p><b>22.06.14</b></p> <p><b>ANNEVILLE</b> CHAMPIONNAT DE FRANCE</p> <ul style="list-style-type: none"> <li>* ENDURANCE</li> </ul>	<p><b>22.06.14</b></p> <p><b>NOGARO</b> CHAMPIONNAT DE FRANCE</p> <ul style="list-style-type: none"> <li>* SUPERKART</li> </ul>
<p><b>29.06.14</b></p> <p><b>LE MANS</b> NSK</p> <ul style="list-style-type: none"> <li>* NATIONALE 150 &amp; 160</li> <li>* KRA 7 &amp; 11 * X30</li> <li>* DD2 &amp; DD2 MASTER</li> <li>* ROTAX MASTER * ROTAX MAX</li> </ul>	<p><b>06.07.14</b></p> <p><b>GROIX EN TERNOIS</b> CHAMPIONNAT DE FRANCE (LONG CIRCUIT)</p> <ul style="list-style-type: none"> <li>* KZ125 * KZ125 GENTLEMAN</li> <li>* COUPE DE FRANCE</li> <li>* SUPERKART</li> </ul>	<p><b>06.07.14</b></p> <p><b>ANGERVILLE</b> CHAMPIONNAT DE FRANCE</p> <ul style="list-style-type: none"> <li>* NATIONALE 150 * NATIONALE 160</li> <li>* COUPE DE FRANCE</li> <li>* HANDIKART * MINI KART</li> </ul>	<p><b>13.07.14</b></p> <p><b>LAVELANET</b> CHAMPIONNAT DE FRANCE</p> <ul style="list-style-type: none"> <li>* FEMININE</li> <li>* CADET</li> <li>* MINIME</li> </ul>
<p><b>13.07.14</b></p> <p><b>WACKERSDORF</b> ACADEMY TROPHY &amp; EUROPEAN CHAMPIONSHIP</p> <ul style="list-style-type: none"> <li>* KZ</li> <li>* KZ2</li> </ul>	<p><b>20.07.14</b></p> <p><b>ZUERA</b> ROTAX EURO CHALLENGE (RACE 3)</p> <ul style="list-style-type: none"> <li>* ROTAX SENIOR</li> <li>* DD2</li> <li>* DD2 MASTER</li> <li>* ROTAX JUNIOR</li> </ul>	<p><b>27.07.14</b></p> <p><b>KRISTIANSTAD</b> EUROPEAN CHAMPIONSHIP</p> <ul style="list-style-type: none"> <li>* KFJ</li> <li>* KZ</li> <li>* KZ2</li> </ul>	<p><b>27.07.14</b></p> <p><b>LOHEAC</b> CHAMPIONNAT DE FRANCE</p> <ul style="list-style-type: none"> <li>* NATIONALE 150</li> <li>* NATIONALE 160</li> <li>* CADET</li> <li>* MINIME</li> </ul>

# ÉCOLE FRANÇAISE DE KARTING



## LE KART ÇA S'APPREND A L'ÉCOLE !

RETROUVEZ L'ÉCOLE FRANÇAISE DE KARTING LA PLUS PROCHE DE CHEZ VOUS EN PARCOURANT LES PAGES DE CE GUIDE OU SUR : [www.ffsa-efk.com](http://www.ffsa-efk.com)

Les Écoles Françaises de Karting vous garantissent un accueil et une prestation de qualité pour apprendre à piloter un kart de compétition en toute sécurité dès l'âge de 6 ans.



Dès 6 ans, le Kart ça s'apprend à l'école !  
Renseignements : [www.ffsa-efk.com](http://www.ffsa-efk.com)





**KSP GRAND**

© Photo KSP - Philippe Kalmès





# SENNA MEMORIAL A SUCCESS DESPITE THE RAIN!







AN UNFORGETTABLE EVENT,  
PERFECTLY CONSISTENT WITH WHAT'S  
EXPECTED FROM THE FIRST EDITION  
OF THE AYRTON SENNA MEMORIAL RACE.



35

Take the unique atmosphere of Imola, carefully prepared to host the event. Add an incredible flood of fans making a pilgrimage to commemorate one of the gods of motorsport. Add the rain, which tested the tenacity and passion of more than a hundred drivers, divided into eighteen teams coming all the way from Italy, Spain, Brazil and Lithuania. Finally, finish with the Parolin Racing XT40 kart with the very reliable Honda GX270, a product that brilliantly withstood the wet conditions by behaving exceptionally under the heavy rain that fell on Imola on Friday, May 2nd. In the end you get an unforgettable event, perfectly consistent with what's expected from the first edition of the Ayrton Senna Memorial race.

Competitors were totally up for this important commemoration. The sprint race began and ended with domination from Luca Filippi, a recognized talent

of Italian motorsport as well as a collaborator with Sky Sports F1. Filippi took pole position ahead of Piergentili Zipoli and then confirmed it in the race to take victory in a deluge, which showed the extent of his driving skills. Behind him was Gabbiani Jr, who made a serious comeback and Zipoli who completed the podium.

In the endurance race, the Rainmaker team - without irony - took pole position, followed by the Porsche and R3 4 Ayrton teams. After a Le Mans-style start, there was six and a half hours of a very competitive race. Different race strategies, sanctions and of course the quality of the team members made a difference. The versatility of driving styles was very important due to the constant changing of the track. The team R3 4 Ayrton proved ultimately the most consistent and took a complete victory by four laps ahead of the Porsche Sport

Driving team, also very competitive, and in addition to the second place, can boast the fastest lap. On the third step of the podium, the Minardi by Pastina & Friends team of brave drivers were delayed by a few hazards, but moved back up to third place. Next was the Sardinian team 4 Mori who were just off the podium thanks to excellent performances. The finish was exciting between Brasil Maranhao and Spain Winner, fifth and sixth respectively. The ranking also saw the Lithuanians of Artkart and GAS Racing Team finish the race a little further back, emphasizing the great value of committed drivers and the amazing spectacle of such an endurance race.

Someone up there is no doubt amused to watch the competitors sympathetically. All participants and grateful fans have sent him a beautiful testimony of love and respect that stands the test of time.



36





# INTERVIEW WITH LUCA DE DONNO

By Frédéric Billet / © Photo KSP - Philippe Kalmès

## WITH AN AVERAGE OF 200 DRIVERS PER EVENT, THE 2014 WSK SUPER MASTER SERIES WAS A GREAT SUCCESS.

An international championship in its own right as well as almost essential preparation before the European Championships, the flagship series from WSK Promotion has changed name several times while maintaining its direction since 2006. Run at La Conca, the last event was an ideal opportunity to take stock with the principal of WSK Promotion, Luca De Donno.

### 2014...

*"The international entry in 2014 for the two series, the WSK Champions Cup and Super Master Series, has proved satisfactory in the light of the global economic situation. All motorsport is affected, not just karting. KF deserves to attract more drivers because it is now a reliable and accessible category. Most ASN have stopped organising races in KF and KF-Junior in their national championships and that's a shame. I think there is work to do on this point, as the WSK, a private organiser, cannot be the only one to support international categories. The ASNs should become more involved in the development of CIK categories, it is part of their mission."*

### THE FUTURE

*"The future lies in the development of classes for very young drivers like 60 Mini and Minikart. Article 18 of the CIK-FIA regulations has hindered the development of 60 Mini by limiting access for foreign drivers. But it is a very formative category for the industry in the context of preparing them to move into cars. There is great potential here that shouldn't be neglected, to ensure the future of KF and KF-Junior."*

### SINGLE-SEATERS

*"The car project we support is closely related to karting. WSK Promotion is collaborating this year with the Italian Federation in the creation of CSAI Italian F4 Championship in accordance with the new specifications of the FIA. F4 should help with the development of karting, opening new attractive opportunities for drivers and the teams in the context of a training system. This strong link should also bring more awareness to karting with the arrival of new partners. The Championship will start soon with 22 cars expected to date. This is a new adventure for us and also a major promotional effort."*





# TECHNOLOGY FOR FUTURE CHAMPIONS

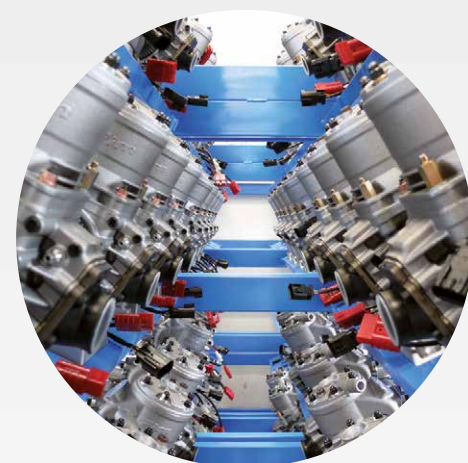

VISIT OUR FACTORY

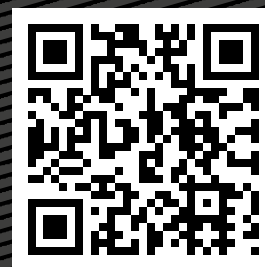

CIK-FIA OFFICIAL PARTNER







# EUROPEAN KF AND KF-JUNIOR CHAMPIONSHIP

ROUND 1 OF 4

## LA CONCA SMILES ON THE BRITISH



By Frédéric Billet / © Photo KSP - Philippe Kalmès

### KEY POINTS OF THE WEEKEND

Date: May 8th to 11th, 2014

Location: La Conca International Circuit, Muro Leccese, Italy - 1242 m

Entry: 134 pilots - 2 categories

→ First meeting of the 2014 CIK-FIA European Championships out of the four rounds. The worst result after the heats and the worst result in the final will be counted.

→ Successful implementation of the new CIK-FIA rule reducing the amount of tyres allowed, without parc fermé, and systematic monitoring using the bar code and the MiniRAE Lite unit.

→ New points system rewarding the top 10 in the intermediate classification, in addition to the top 15

in the Final. Up to 20 drivers in each category scored points during the first event.

→ A lovely meeting in the sun, very interesting racing with suspense, a good sporting atmosphere, high quality organisation, deserving winners in the finals, but still too many incidents at the first corner and the first hairpin after the start.

→ We noticed increased severity - which was universally appreciated - from the CIK-FIA Stewards who distributed a lot of penalties for bad behavior on the track, even using the black flag. The management is good!





# ILOTT, THE WINNER AND LEADER IN KF

Although Callum Ilott (Zanardi-Parilla-Dunlop) eventually won the KF category it was another Briton, Lando Norris (FA Kart-Vortex-Dunlop) who dominated since Timed Qualifying on Friday afternoon. The young Norris, who has moved up to KF this year after winning the CIK-FIA European Championship in KF-Junior last year, continued his momentum by winning all his Qualifying Heats. However Ilott won the Prefinal, taking advantage of the attack from the Spanish driver Pedro Hiltbrand (CRG-TM-Dunlop) on the favourite on the first lap to infiltrate into the breach and take the lead of the race. Ilott started perfectly with the lights of the Final, then escaped to cross the finish line as the winner by more than two seconds ahead of the Finn Niko Kari (Tony Kart-Vortex-Dunlop), one of the revelations of the weekend. Battered early in the race, Norris did not admit defeat and climbed up from 6th position despite an already large gap with the leader. He set the fastest lap of the race and reached the third step of the podium. The 4th place for the Italian Felice Tiene (CRG-TM-Dunlop) deserves special mention as he started from 25th place on the grid.

Callum Ilott has taken the lead in the CIK-FIA European KF Championship with 34 points, ahead of 2nd Lando Norris (26 points), Niko Kari in 3rd (20 points), Pedro Hiltbrand 4th (19 points) and Felice Tiene 5th (18 points).



# AHMED WINS KF-JUNIOR IN THE END

There was a fairly similar scenario in the KF-Junior category. Indeed, the American Devlin Defrancesco (Tony Kart-Vortex-Vega) began by imposing in Timed Qualifying and in three of his four Qualifying Heats and finally the Prefinal. Nevertheless, the competition reacted during the Final where Defrancesco was relegated to 8th position on the first time over the timing line. Started by the British driver Enaam Ahmed (FA Kart-Vortex-Vega), the attack allowed him to get away and prevent a possible comeback from Defrancesco. Logan Sargeant (FA Kart-Vortex-Vega), another American, would not let anyone take 2nd position away from him at the chequered flag and Defrancesco had to settle for 3rd place. The Russian Alexander Vartanyan (Tony Kart-Vortex-Vega) finished 4th ahead of the Italian Leonardo Lorandi (Tony Kart-TM-Vega).

Enaam Ahmed is the leader of the standings of the CIK-FIA European KF-Junior Championships with 31 points, Devlin Defrancesco 2nd (26 points), Logan Sargeant 3rd (20 points), Mick Junior 4th (18 points) and Alexander Vartanyan 5th (17 points).





By Frédéric Billet / © Photo KSP - Philippe Kalmès

EUROPEAN KF AND KF-JUNIOR CHAMPIONSHIP LA CONCA

# AUBRY IN THE EUROPEAN TOP 10 AT LA CONCA

GABI-AUBRY.FR

Always fast, Gabriel Aubry was the most effective driver from the Tony Kart Racing Team at Muro Leccese, in the first round of the 2014 European KF Championship at the La Conca circuit. This positive balance has resulted in 9th place in the standings with three races still to go.

After a very successful free practice where he set the fastest time of the last two sessions, Gabriel's qualifying was not made easy by the simultaneous presence of 33 drivers on the track, especially in the second session which did not have optimal grip like the first session which ran on the rubber of the Vega KFJ tyres. He set an excellent second fastest time, six hundredths off the leader, but was only 11th overall.

In the first heat, Aubry crashed under braking on the 2nd lap and dropped to 17th. A little edgy, he moved back up to 10th with the fastest time. 3rd and 2nd with another fastest lap, he had to fight back to 8th in the last heat after dropping to 17th early in the race during an incident, while his Tony Kart / Vortex had not yet reached its best level of performance. However, the situation

remained favourable with 11th position in the intermediate classification.

During the finals, the challenge was twofold: start smoothly and manage the first few laps until the machine starts running, as the experts say. A wise race led Gabriel to 8th position in the prefinal. After a satisfactory start in the final, despite a spot on the outside lane, and 7th position on the 2nd lap, he then dropped to 12th position on lap 6 after an attack on an animated group, then he came back to eighth position in the wheeltracks of Nicklas Nielsen, taking the best French result of the competition.

*"I am not happy with the European meeting at La Conca," explained Aubry later. "I was very fast at the beginning of the weekend, but I lost a bit of performance in the finals to be able to run at the front. I managed well, and the goal is to score championship points. I am currently 9th, which is not so bad, and I hope to do better soon at Zuera with a more competitive kart."*







By Frédéric Billet / © Photo KSP - Philippe Kalmès

EUROPEAN KF AND KF-JUNIOR  
CHAMPIONSHIP LA CONCA

# DEFRANCESCO ATTACKS THE EUROPEAN CHAMPIONSHIP

DEVLINDEFRANCESCO.COM

# DEFRANCESCO

Although the most recent round of the WSK Super Masters didn't bring the expected results, Devlin DeFrancesco enjoyed great success at the first round of the European KF-Junior Championship two weeks later at the same circuit of La Conca in southern Italy. A very competitively set-up Tony Kart-Vortex, developed by the Morsicani Racing team, enabled the young American driver to monopolise the top spots for most of the race weekend. Devlin is also in second place in the provisional standings of the CIK-FIA championship.

With great clarity, he analyzed the reasons for his third-place finish in the press conference: *"It's my fault, I tried a middle line at the start, when I was in pole position, to carry more speed. It had worked for me at Sarno, but it didn't work here. After that I gave everything at each corner to remake the lost ground, without thinking about the result. It was very hard physically."*

The meeting was marked by outstanding performances from DeFrancesco. The team put in a lot of development work during free practice and everything was in order for qualifying, with Devlin taking pole, a tenth faster than his pursuers. He then won three out of his four heats, finishing second in the last and took another win in the prefinal with an lead of 3.6" after the 13 laps. The final started badly, causing Devlin to wobble several times after the start and he finished the first lap in 8th place. His reaction was immediate and he began a courageous climb to third position, but the top two were too far away to be reached.

The balance was ultimately very satisfying at the end of the first European round at La Conca. Devlin is in second place in the provisional standings, five points behind the leader, and there are still three events to go.





# LÉGERET MAKES GREAT STRIDES

By Frédéric Billet

© Photo KSP - Philippe Kalmès

EUROPEAN KF AND KF-JUNIOR  
CHAMPIONSHIP LA CONCA

LUCAS-LEGERET.CH

# LEGERET

The young Swiss driver Lucas Légeret is following an amazing journey in his first KF-Junior races. Just out of Mini 60, Lucas didn't take long to familiarise himself with the higher category. After some strong bursts in the WSK Super Master Series, he showed great maturity in the first round of the European Championship at La Conca.

Lucas already set the 9th fastest time in his session at the wheel of his Zanardi / Parilla run by the Zanardi Strakka team. In the heats, his performance was remarkable, often with fastest laps, but the intensity of the fighting in the pack did not help him. He qualified for the finals by driving a good race in the repechage, as always perilous, and gained no less than 15 places in the prefinal, demonstrating his strength in battle. Lucas gained more in final: in 27th after the first lap after a tumultuous start, he came back again to 18th position.

Mission accomplished for the first European event, a very physical competition where rookies like Lucas often find it difficult to get a place. He now looks forward to Spain on the fast Zuera track and new adventures.



By Frédéric Billet / © Photo KSP - Philippe Kalmès

EUROPEAN KF AND KF-JUNIOR CHAMPIONSHIP LA CONCA

# PULL ON THE PACE AT FIRST ROUND OF EUROS AT LA CONCA

James Pull demonstrated that he is a serious contender in the European KF-Junior Championship in 2014 despite having to retire in the final for mechanical reasons at the La Conca circuit in Italy.

Showing great consistency since the start of the meeting, James took an excellent hard-won fourth position in the prefinal and the McLaren Performance Academy British driver from the Tony Kart Racing Team has established himself among the top specialists in KF-Junior. We saw positive signs, driving his Tony Kart / Vortex, with the fourth fastest time in

his group during qualifying, which put him in 14th place in the category, largely because of changes in track conditions between the groups. He continued the European competition with excellent runs in the qualifying heats, regularly finishing in the top five and posting the fastest lap in his last heat despite dropping from 3rd to 21st as a result of another driver running into him at turn 3 with only a few laps left.

Even with the incident in the last heat, the Singapore born driver saw his efforts rewarded with 11th place in the intermediate classification. Starting from

the 6th row in the prefinal, James made a superb start and very quickly moved to the front of the race which he eventually finished fourth.

James was confident of a podium finish in the final, but fate decided differently on lap 5. An incident demoted him to the bottom of the standings before causing his retirement. James is now focused on testing and preparing himself for the next European event in Spain on the fast Zuera track.

JAMESPULLRACING.COM



EUROPEAN  
KF AND KF-JUNIOR  
CHAMPIONSHIP  
LA CONCA





EUROPEAN KF AND KF-JUNIOR  
CHAMPIONSHIP LA CONCA

# XIA YIFAN, AN ALREADY PRO- MISING TALENT IN KARTING

By Frédéric Billet / © Photo KSP - Philippe Kalmès

**M**aking his debut in the international KF category, the elite of non-gearbox karts, the young Chinese driver Xia Yifan has been achieving more and more convincing results since the beginning of the 2014 European season. During the first round of the CIK-FIA European Championship, he was consistently ranked in the top 10 against the world's best specialists.

An excellent tennis player, Yifan Xia discovered karting in Florida. Participating in several races in Rotax MiniMax in the Florida Winter Tour at the age of 11, his ability soon put him in the top 10 of the young drivers. Very

quickly, he realized he would have to go to Europe if he wanted to progress more quickly. After two years of apprenticeship in KF3, with his entourage they decided to give themselves the best chance of succeeding by coming to live in Italy, the home of karting, in order to intensify his training. Therefore in 2014 he started in the category for karts without gearboxes, KF, within a team known for being friendly but serious; Kartronix International, the Irish team run by Jarlath Keary.

With this choice, his progress exceeded expectations. While he had struggled to qualify for the finals in KF-Junior last

year, he is now able to fight in the top 10 of KF with his Tony Kart chassis and TM engine. He scored a great 8th place in the final of the WSK Super Master Series at Castelletto (ITA). He finished 12th two weeks later at La Conca (ITA) and was 17th overall in this very tough series.

Things really got serious with the first round of the CIK-FIA European Championship, again at the La Conca circuit. Prepared by a busy start to the season in various competitions, and taking advantage of the lessons provided by his team, Yifan was 14th in qualifying among 67 competitors

and improved his score in the heats, taking 10th place at the end. He then maintained 11th in the prefinal, but had to retire on the 2nd lap of the finals after a collision. It was a disappointment that doesn't hide the amazing progress Yifan has made since the beginning of the season and let's hope there will be nice contrast at the next European event at Zuera, Spain.





## RÉSULTS



P.	Pilote	Nat.	Mat.	Chr.	Tps.	Inter.	Pre-Fin.	Tps	Fin.	Tps
1	Ilott Callum	GB	ZANARDI / PARILLA	3	46"567"	2	1	46"619"	1	46"774"
2	Kari Niko	FIN	TONY KART / VORTEX	17	46"854"	15	5	46"789"	2	46"800"
3	Norris Lando	GB	FA KART / VORTEX	1	46"324"	1	2	46"622"	3	46"718"
4	Tiene Felice	I	CRG / TM	11	46"696"	6	25	46"994"	4	46"780"
5	Hiltbrand Pedro	E	CRG / TM	2	46"822"	3	3	47"028"	5	46"906"
6	Van Leeuwen Martijn	NL	ZANARDI / PARILLA	20	47"019"	17	4	46"881"	6	46"910"
7	Nielsen Nicklas	DK	KOSMIC / VORTEX	5	46"644"	4	6	46"891"	7	46"987"
8	Aubry Gabriel	F	TONY KART / VORTEX	4	46"886"	11	8	46"904"	8	46"807"
9	Basz Karol	PL	TONY KART / VORTEX	7	46"660"	7	7	46"902"	9	47"004"
10	Joyner Tom	GB	ZANARDI / PARILLA	25	46"928"	16	18	46"833"	10	46"902"
11	Sitnikov Nikita	RUS	TONY KART / PARILLA	19	46"905"	13	9	46"907"	11	46"987"
12	Lundgaard Daniel	DK	TONY KART / VORTEX	21	46"919"	27	23	46"991"	12	46"935"
13	Dabski Karol	PL	PRAGA / PARILLA	15	46"846"	20	21	47"047"	13	47"058"
14	Norris Oliver	GB	FA KART / VORTEX	30	47"125"	19	20	46"953"	14	46"966"
15	Pulcini Leonardo	I	ENERGY / TM	12	46"965"	25	10	47"139"	15	47"054"
16	Daruvala Jehan	IND	FA KART / VORTEX	9	46"688"	8	14	46"948"	16	47"094"
17	Rossel Kevin	DK	TONY KART / TM	41	47"092"	28	30	47"912"	17	47"117"
18	Mazepin Nikita	RUS	TONY KART / VORTEX	6	46"902"	9	12	47"041"	18	46"893"
19	Stupenkov Egor	RUS	ENERGY / TM	29	46"949"	26	32	48"643"	19	47"078"
20	Hodgson Oliver	GB	KOSMIC / TM	45	47"259"	41	15	46"955"	20	47"100"
21	Fong Wei Jie Julien	SGP	TONY KART / TM	13	46"719"	23	24	46"912"	21	47"177"
22	Skaras Emil	S	TONY KART / VORTEX	24	47"087"	21	17	47"252"	22	47"246"
23	Heinonen Johannes	FIN	ZANARDI / PARILLA	62	47"606"	44	26	47"353"	23	47"502"
24	Zhou Guan Yu	CHN	FA KART / VORTEX	16	46"985"	14	P 28	47"258"	24	47"035"
25	Kjaergaard Nicolai	I	ENERGY / TM	26	47"094"	33	31	47"300"	25	47"361"
26	Darras Julien	F	KOSMIC / VORTEX	66	55"817"	29	16	47"171"	26	47"198"
27	Lorandi Alessio	I	TONY KART / TM	8	46"924"	5	33	47"087"	27	47"087"
28	Okada Takuya	J	ART GP / TM	22	47"033"	39	27	47"383"	28	47"968"
29	Moilanen Aatu	FIN	ART GP / TM	23	46"923"	18	22	47"417"	29	47"720"
30	Xia Yifan	CHN	TONY KART / TM	14	46"971"	10	11	46"892"	30	49"631"
31	Maestranzi Marco	I	TOP KART / TM	10	46"945"	24	13	47"052"	31	
32	Marcu Dionisios	RO	CRG / TM	37	47"040"	30	19	47"123"	32	
33	Puhakka Juuso	FIN	KOSMIC / VORTEX	18	47"014"	12	34			EX
34	Marino Sato	THA	PRAGA / PARILLA	33	46"977"	22	29	47"250"		EX
35	Besancenez Paolo	F	TONY KART / TM	27	46"946"	55				
36	Janker Hannes	D	ZANARDI / PARILLA	48	47"392"	62				
37	Lavelli Kevin	I	TOP KART / PARILLA	64	47"630"	32				
38	Chaimongkol Sasakorn	TW	BIREL / TM	34	47"175"	61				
39	Grzyb Michal	PL	BIREL / TM	50	47"394"	52				
40	Gonzales Nicolas	F	KOSMIC / PARILLA	58	47"514"	42				
41	Pankiewicz Wiktoria	PL	TONY KART / TM	53	47"368"	46				
42	Korneev Alexey	D	TONY KART / VORTEX	40	47"223"	40				
43	Cucco Stefano	I	BIREL / TM	52	47"404"	38				
44	Troickiy Nikita	RUS	TONY KART / VORTEX	67	48"172"	50				
45	Martynyuk Maxim	I	ENERGY / TM	46	47"385"	58				
46	Gadois Alexandre	F	KOSMIC / PARILLA	54	47"431"	56				
47	Gomez Sidney	VEN	CRG / TM	51	47"318"	45				
48	Kim Maxim	RUS	DR / TM	35	46"995"	37				
49	Sette Camara Sergio	BRA	ART GP / TM	32	47"168"	48				
50	Thorsen Kristian	DK	ENERGY / TM	63	47"654"	54				
51	Van Der Watt Julian	ZA	ZANARDI / PARILLA	55	47"374"	53				
52	Durante Cosimo Francesco	I	KOSMIC / VORTEX	65	47"744"	59				
53	Hall Philip	S	TONY KART / VORTEX	42	47"247"	34				
54	Al-khalifa Issa Bin Abdulla	BHR	TONY KART / TM	60	47"577"	57				
55	Tujula Tuomas	FIN	ART GP / TM	36	47"186"	31				
56	Mantyla Ville	FIN	KOSMIC / VORTEX	44	47"263"	60				
57	Horn Moritz	D	ENERGY / TM	43	47"105"	36				
58	Semi Valtteri	FIN	KOSMIC / VORTEX	59	47"456"	43				
59	Lundqvist Linus	S	TONY KART / VORTEX	39	47"077"	49				
60	Potty Maxime	B	KOSMIC / PARILLA	56	47"500"	47				
61	Haapalainen Tuomas	FIN	ART GP / TM	28	47"124"	35				
62	Shlom Yan Leon	RUS	TONY KART / TM	31	46"963"	51				
63	Von Schedvin Lina	S	BIREL / TM	38	47"217"	63				
64	Cristofaro Nick	GB	TONY KART / TM	47	47"292"	64				
65	Klar David	CZ	ART GP / TM	49	47"292"	65				
66	Dante Zackary	USA	DR / TM	57	47"412"	66				
67	Pym Hannah	GB	TONY KART / TM	61	47"591"	67				

KF ★ DUNLOP

P.	Pilote	Nat.	Mat.	Chr.	Tps.	Inter.	Pre-Fin.	Tps	Fin.	Tps
1	Ticktum Daniel	GB	ZANARDI / PARILLA	38	47"675"	22	11	47"926"	10	47"919"
2	Ahmed Enaam	GB	FA KART / VORTEX	5	47"354"	5	3	47"588"	1	47"567"
3	Sargeant Logan	USA	FA KART / VORTEX	3	47"269"	23	7	47"586"	2	47"520"
4	Azedo Sousa Yohan	P	ZANARDI / PARILLA	63	48"320"	58				
5	Lorandi Leonardo	I	TONY KART / TM	27	47"550"	14	9	47"645"	5	47"640"
6	Floersch Sophia	D	TONY KART / TM	35	47"654"	40				
7	Bollier Jules	F	KOSMIC / PARILLA	16	47"459"	9	22	47"789"	32	48"317"
8	Lessennes Benjamin	B	KOSMIC / PARILLA	13	47"397"	19	33	52"378"	P 17	47"489"
9	Garcia Lopez Marta	E	ZANARDI / PARILLA	20	47"504"	51				
10	Vartanyan Alexander	RUS	TONY KART / VORTEX	47	47"786"	7	8	47"699"	4	47"601"
11	Mick Junior	D	TONY KART / VORTEX	4	47"290"	2	5	47"590"	7	47"647"
12	Travisanutto Lorenzo	I	PCR / TM	54	47"896"	25	12	47"833"	14	47"967"
13	Baiz Mauricio	VEN	LH / TM	21	47"512"	47				
14	Krencisz Jan	PL	KOSMIC / VORTEX	61	48"064"	45				
15	Beckmann David	D	TONY KART / VORTEX	2	47"263"	16	31	47"924"	8	47"736"
16	Martin Ross	GB	TONY KART / TM	12	47"396"	18	14	47"805"	9	47"878"
17	Fewtrell Max	GB	FA KART / VORTEX	8	47"369"	10	10	47"587"	6	47"583"
18	Pull James	GB	TONY KART / VORTEX	14	47"412"	11	4	47"647"	31	47"885"
19	Tillett Archie	GB	LH / TM	52	47"855"	27	21	48"105"	26	48"199"
20	Moreira Laliberte Kami	CAN	TONY KART / TM	19	47"503"	15	16	47"793"	16	47"888"
21	Smith Joshua Francis	GB	ART GP / TM	23	47"524"	41				
22	Defrancesco Devlin	USA	TONY KART / VORTEX	1	47"155"	1	1	47"439"	3	47"533"
23	Alesi Giuliano	F	TONY KART / TM	48	47"803"	66				
24	Colombo Lorenzo	I	TONY KART / TM	46	47"767"	38				
25	Drugovich Felipe	BRA	TONY KART / TM	31	47"588"	59				
26	Maini Kush	IND	TONY KART / TM	49	47"832"	26	25	47"972"	13	47"876"
27	Martono Presley	RO	TONY KART / TM	22	47"513"	31	24	47"977"	22	47"931"
28	Mazrul Haizad Adam	MYS	ART GP / TM	64	48"394"	64				
29	Ye Yifei	CHN	ART GP / TM	40	47"708"	50				
30	Pasma Patrik	FIN	ART GP / TM	51	47"853"	49				
31	Tontieri Paaavo	FIN	ART GP / TM	28	47"554"	20	P 27	47"627"	11	47"888"
32	Alex	I	DR / TM	9	47"395"	13	15	48"112"	30	47"818"
33	Lappalainen Konsta	FIN	TONY KART / VORTEX	24	47"528"	24	29	47"836"	25	47"790"
34	Tashkalov Damir	RUS	TONY KART / VORTEX	60	48"002"	55				
35	Zotov Gleb	RUS	TONY KART / VORTEX	43	47"745"	53				
36	Konstantinos	GR	LH / TM	50	47"851"	60				
37	Martinez Merono Eliseo	E	LH / TM	18	47"488"	4	6	47"659"	33	
38	Petrov Artem	RUS	DR / TM	17	47"465"	8	23	47"624"	19	47"609"
39	Baciуска Rokas	LT	ENERGY / TM	39	47"697"	44				
40	Correa Juan	USA	ENERGY / TM	7	47"359"	12	28	47"810"	12	47"629"
41	Brozzoni Alessandro	F	ENERGY / TM	65	48"591"	67				
42	Naicker Kashen	ZA	ZANARDI / PARILLA	66	48"679"	62				
43	Viscaal Bent	NL	ZANARDI / PARILLA	45	47"766"	56				
44	Legeret Lucas	CH	ZANARDI / PARILLA	30	47"582"	36	18	47"724"	18	47"837"
45	Gheno Jacopo	I	TONY KART / TM	58	47"937"	54				
46	Lloveras Brunet Xavier	E	FA KART / VORTEX	44	47"762"	46				
47	Pankiewicz Julia	PL	TONY KART / TM	56	47"931"	39				
48	Munoz Fernandez Adrian	E	TONY KART / VORTEX	33	47"640"	43				
49	Santos Gomez Lisard	E	TONY KART / VORTEX	53	47"889"	28	26	48"128"	29	48"087"
50	Eriksson Joona	FIN	KOSMIC / VORTEX	62	48"267"	63				
51	Sario Robin	FIN	KOSMIC / VORTEX	59	47"963"	57				
52	Haaga Anton	S	LENZOKART / LKE	15	47"448"	6	34		28	47"961"
53	Lenzo Federico	I	LENZOKART / LKE	34	47"641"	37				
54	Lindh Rasmus	B	PRAGA / PARILLA	29	47"560"	42				
55	Podobsky Lukas	CZ	PRAGA / PARILLA	55	47"927"	65				
56	De Pauw Ulysse	B	KOSMIC / PARILLA	10	47"395"	17	2	47"466"	15	47"635"
57	Roes Casper	DK	ENERGY / TM	25	47"528"	32	19	47"902"	20	47"740"
58	Roosens Kenny	B	ZANARDI / TM	36	47"655"	33				
59	Yue Yang Sun	CHN	FA KART / VORTEX	26	47"542"	35	13	47"725"	24	47"755"
60	Milesi Charles	F	TONY KART / PARILLA	41	47"709"	48				
61	Fernandez Wahbeh Sebastian	I	KOSMIC / TM	11	47"396"	3	32	48"197"	21	47"904"
62	Verkroost Bard	NL	TONY KART / TM	37	47"665"	30	17	47"805"	27	48"624"
63	Lundgaard Christian	DK	TONY KART / VORTEX	32	47"629"	21	20	47"951"	34	
64	Leuillet Tom	F	BIREL / TM	57	47"936"	52				
65	Novalak Clement	CH	KOSMIC / VORTEX	6	47"355"	29	30	47"840"	23	47"870"
66	Van Kalmthout Rinus	B	ZANARDI / PARILLA	67	49"396"	34				
67	Milell Noah	S	EXPRIT / VORTEX	42	47"741"	61				

KFJ ★ VEGA



**NATIONALY**

ITALIE	16	■
ROYAUME-UNI	14	■
FINLANDE	13	■
FRANCE	10	■
FEDERATION DE RUSSIE	10	■
POLOGNE	6	■
BELGIQUE	6	■
ALLEMAGNE	6	■
SUEDE	6	■
ESPAGNE	6	■
DANEMARK	6	■
CHINE	4	■
ETATS-UNIS	4	■
PAYS-BAS	3	■
SUISSE	2	■
BRESIL	2	■
AFRIQUE DU SUD	2	■
REPUBLIQUE TCHEQUE	2	■
INDE	2	■
VENEZUELA	2	■
ROUMANIE	2	■
SINGAPOUR	1	■
BAHREIN	1	■
PROVINCE CHINOISE DE TAIWAN	1	■
LITUANIE	1	■
THAILANDE	1	■
JAPON	1	■
GRECE	1	■
MALAISIE	1	■
CANADA	1	■
PORTUGAL	1	■

**CHASSIS**

TONY KART	45	■
KOSMIC	18	■
ZANARDI	14	■
ART GP	11	■
ENERGY	10	■
FA KART	9	■
BIREL	5	■
CRG	4	■
DR	4	■
LH	4	■
PRAGA	4	■
TOP KART	2	■
LENZOKART	2	■
PCR	1	■
EXPRIT	1	■

**ENGINES**

TM	65	■
VORTEX	41	■
PARILLA	26	■
LKE	2	■

**TIRES**

VEGA	67	■
DUNLOP	67	■



**THE KART SHOP!**  
helmets, kart suits, accessories...

**EVERYTHING  
YOU NEED IS ON  
ITAKASHOP.COM!**

+ than 6000  
references!



[www.itakashop.com](http://www.itakashop.com)



# EUROPEAN KF AND KF-JUNIOR CHAMPIONSHIP

ROUND 2 OF 4

By Frédéric Billet / © Photo KSP - Philippe Kalmès

## TENSION MOUNTS AT ZUERA



### KEY POINTS OF THE WEEKEND

Date: May 29th to June 1st, 2014

Location: Zuera International Circuit, Spain - 1700 m

Entry: 114 drivers - 2 categories

→ Second joint meeting of the 2014 CIK-FIA European Championships.

→ The track at Zuera enabled new winners and opened up the struggle for European victory, both for drivers and equipment.

→ Swedish driver Anton Haaga (Kosmic / LKE) took his first win in KF-Junior. Enaam Ahmed (FA Kart / Vortex) and Devlin DeFrancesco (Tony Kart / Vortex) narrowly retained their advantage in the championship.

→ Nicklas Nielsen (Kosmic / Vortex) topped the standings in KF ahead of Lando Norris (FA Kart / Vortex) and Niko Kari (Tony Kart / Vortex). Tom Joyner (Zanardi / Parilla) won the final.





## JOYNER BACK IN THE TITLE RACE

The 2013 World Champion has demonstrated a special talent of being in the right position at the right time. At Zuera, Tom Joyner (Zanardi-Parilla-Dunlop) was always among the fastest. 8th

in timed qualifying, he was 5th after the qualifying heats before finishing 3rd in the prefinal. In the final, the British driver took the lead on the 8th of the 18 laps, then escaped permanently to victory. His compatriot Callum Ilott (Zanardi-Parilla-Dunlop) set the fastest time, however, the Italian Felice Tiene (CRG-TM-Dunlop) was leading at the end of the qualifying heats, and the Dane Nicklas Nielsen (Kosmic-Vortex-Dunlop) won the prefinal. So the competition was always open. Ilott was forced to retire in the prefinal and could not

make up the ground in the final. Tiene proved to be less competitive in the finals, while Nielsen fought to the end of the final to retain his second place against the Italian Alessio Lorandi's (Tony Kart-TM-Dunlop) recovery from 9th position.

In the provisional standings of the Championship, Nicklas Nielsen ranks first equal on points with Lando Norris, Niko Kari is in third position, ahead of Tom Joyner, Callum Ilott and Felice Tiene.

# HAAGA, A REVELATION FROM SWEDEN

A driver unaccustomed to international awards starred in KF-Junior throughout the Spanish weekend. 15 years old, the Swede Anton Haaga (Kosmic-LKE-Vega) hasn't had the opportunity to compete in full seasons in 2012 and 2013 due to accident injuries. His sense of attack had been noticed earlier this year, but this is the first time that it translated into a great victory, essentially in a small family team. It is also the first success for an LKE engine at this level. Haaga was first took second in timed qualifying, before an uninterrupted series of wins. His four consecutive fastest laps in the qualifying heats attest to his performance. Winning on his own in the Prefinal, he also demonstrated great potential in the battle in the final. The Briton Daniel Ticktum (Zanardi-Parilla-Vega) and the German Mick Junior (Tony Kart-Vortex-Vega) challenged him for the lead several times, while the Russian Artem Petrov (DR-TM-Vega), as a newcomer to the leading group, and the Belgian Benjamin Lessennes (Kosmic-Parilla-Vega) battled hard. Ticktum finally took the second step of the podium. The other British driver Enaam Ahmed (FA Kart-Vortex-Vega) took the 3rd step after a superb recovery of 15 positions. The U.S. polesitter Devlin Defrancesco (Tony Kart-Vortex-Vega), meanwhile recovered from 30th to 5th position in the final, following a prefinal retirement.

Enaam Ahmed retains the lead in the provisional European KF-Junior Championship, with a small advantage from Devlin Defrancesco, Anton Haaga has in one shot moved up to 3rd place, in front of Logan Sargeant and Daniel Ticktum.





# FRENCH DRIVERS IN THE RACE

The best performance was to the credit of Paolo Besancenez (Tony Kart / TM), twice 3rd in the heats and 6th in the final in KF. Not as fast as he had hoped, Julien Darras (Kosmic / Vortex) finished 13th while Nicolas Gonzalez (Kosmic / Parilla) was ranked 22nd despite a constant engine deficit. Gabriel Aubry (Tony Kart / Vortex) recovered beautifully from 57th to 11th position in the heats before being penalised in the prefinal and retiring in the final. Alexander Gadois (FA Kart / Parilla) failed to qualify in the repechage.

The surprise of the weekend came from Tom Leuillet (Birel / TM), fifth in the KF-Junior repechage and recovering to 14th position in the final. Charles Milesi (Tony Kart / Parilla) had his competition interrupted on Saturday after injury, Giuliano Alesi (Tony Kart / TM) did not qualify for the final, while Alessandro Brozzoni (Energy / TM) continued to learn the category.





P.	Pilote	Nat.	Mat.	Chr.	Tps.	Inter.	Pre-Fin.	Tps	Fin.	Tps
1	Joyner Tom	GB	ZANARDI / PARILLA	8	01'01"566"	5	3	01'01"204"	1	01'01"465"
2	Nielsen Nicklas	DK	KOSMIC / VORTEX	2	01'01"310"	3	1	01'01"229"	2	01'01"496"
3	Lorandi Alessio	I	TONY KART / TM	12	01'01"642"	9	9	01'01"358"	3	01'01"509"
4	Kari Niko	FIN	TONY KART / VORTEX	5	01'01"436"	2	4	01'01"174"	4	01'01"312"
5	Norris Lando	GB	FA KART / VORTEX	4	01'01"398"	4	2	01'01"121"	5	01'01"485"
6	Besancenez Paolo	F	TONY KART / TM	17	01'01"771"	19	13	01'01"254"	6	01'01"659"
7	Tiene Felice	I	CRG / TM	6	01'01"471"	1	5	01'01"199"	7	01'01"619"
8	Maestranzi Marco	I	TOP KART / TM	11	01'01"626"	31	14	01'01"424"	8	01'01"565"
9	Basz Karol	PL	TONY KART / VORTEX	3	01'01"321"	12	31	01'01"396"	9	01'01"381"
10	Rossel Kevin	DK	TONY KART / VORTEX	33	01'01"941"	22	22	01'01"494"	10	01'01"751"
11	Hiltbrand Pedro	E	CRG / TM	20	01'01"785"	20	15	01'01"560"	11	01'01"777"
12	Janker Hannes	D	ZANARDI / PARILLA	14	01'01"678"	15	10	01'01"271"	12	01'01"363"
13	Darras Julien	F	KOSMIC / VORTEX	28	01'01"869"	26	12	01'01"499"	13	01'01"979"
14	Mazepin Nikita	RUS	TONY KART / VORTEX	19	01'01"782"	10	7	01'01"302"	14	01'01"502"
15	Stupenkov Egor	RUS	TONY KART / TM	38	01'01"993"	14	23	01'01"431"	15	01'01"526"
16	Van Leeuwen Martijn	NL	ZANARDI / PARILLA	41	01'02"037"	16	6	01'01"193"	16	01'01"971"
17	Okada Takuya	J	ART GP / TM	25	01'01"835"	32	24	01'01"744"	17	01'01"834"
18	Heinonen Johannes	FIN	ZANARDI / PARILLA	18	01'01"774"	36	18	01'01"674"	18	01'01"950"
19	Lavelli Kevin	I	TOP KART / PARILLA	24	01'01"825"	23	33	01'02"369"	19	01'01"799"
20	Ilott Callum	GB	ZANARDI / PARILLA	1	01'01"247"	8	34		20	01'01"482"
21	Shlom Yan Leon	RUS	TONY KART / TM	29	01'01"892"	27	32	01'01"594"	21	01'01"782"
22	Gonzales Nicolas	F	KOSMIC / PARILLA	42	01'02"040"	24	21	01'01"758"	22	01'01"946"
23	Xia Yifan	CHN	TONY KART / TM	22	01'01"803"	21	17	01'01"583"	23	01'01"971"
24	Troickiy Nikita	RUS	TONY KART / VORTEX	31	01'01"928"	18	11	01'01"332"	24	01'01"755"
25	Lundqvist Linus	S	TONY KART / VORTEX	27	01'01"868"	40	26	01'01"742"	25	01'02"139"
26	Dabski Karol	PL	PRAGA / PARILLA	7	01'01"478"	6	20	01'02"027"	26	01'02"164"
27	Horn Moritz	D	ENERGY / TM	56	01'03"330"	25	25	01'01"685"	27	01'02"001"
28	Moilanen Aatu	FIN	ART GP / TM	53	01'02"528"	29	19	01'01"700"	28	01'01"984"
29	Daruvala Jehan	IND	FA KART / VORTEX	9	01'01"600"	7	8	01'01"552"	29	01'01"962"
30	Hodgson Oliver	GB	KOSMIC / TM	16	01'01"750"	34	29	01'01"885"	30	01'02"169"
31	Puhakka Juuso	FIN	KOSMIC / VORTEX	34	01'01"958"	28	16	01'01"515"	31	
32	Cristofaro Nick	GB	TONY KART / TM	30	01'01"909"	13	27	01'01"883"	32	
33	Aubry Gabriel	F	TONY KART / VORTEX	57	01'10"437"	11	P 30	01'01"547"	33	
34	Pulcini Leonardo	I	ENERGY / TM	15	01'01"680"	17	28	01'01"783"	NQ	
35	Hall Philip	S	TONY KART / VORTEX	23	01'01"812"	30				
36	Cucco Stefano	I	BIREL / TM	59		46				
37	Durante Cosimo Francesco	I	KOSMIC / VORTEX	40	01'02"032"	39				
38	Lundgaard Daniel	DK	TONY KART / VORTEX	43	01'02"042"	37				
39	Semi Valtteri	FIN	TONY KART / VORTEX	58		44				
40	Pankiewicz Wiktoria	PL	TONY KART / TM	10	01'01"622"	33				
41	Sette Camara Sergio	BRA	TONY KART / VORTEX	47	01'02"119"	43				
42	Fong Wei Jie Julien	SGP	TONY KART / TM	26	01'01"863"	50				
43	Skaras Emil	S	TONY KART / VORTEX	39	01'02"010"	54				
44	Potty Maxime	B	KOSMIC / PARILLA	45	01'02"075"	38				
45	Marcu Dionisios	RO	CRG / TM	44	01'02"056"	42				
46	Van Der Watt Julian	ZA	ZANARDI / PARILLA	55	01'02"656"	53				
47	Tujula Tuomas	FIN	ART GP / TM	21	01'01"797"	58				
48	Pym Hannah	GB	TONY KART / TM	50	01'02"199"	48				
49	Korneev Alexey	D	TONY KART / VORTEX	46	01'02"099"	59				
50	Noval Cueto Miguel	E	KOSMIC / TM	54	01'02"583"	56				
51	Grzyb Michal	PL	BIREL / TM	48	01'02"139"	51				
52	Norris Oliver	GB	FA KART / VORTEX	32	01'01"930"	41				
53	Kjaergaard Nicolai	I	ENERGY / TM	35	01'01"960"	47				
54	Gomez Sidney	VEN	CRG / TM	36	01'01"964"	55				
55	Von Schedvin Lina	S	BIREL / TM	49	01'02"149"	52				
56	Gadois Alexandre	F	FA KART / PARILLA	37	01'01"987"	49				
57	Chaimongkol Sasakorn	TW	BIREL / TM	13	01'01"673"	35				
58	Haapalainen Tuomas	FIN	ART GP / TM	51	01'02"212"	45				
59	Klar David	CZ	ART GP / TM	52	01'02"306"	57				

KF ★ DUNLOP

P.	Pilote	Nat.	Mat.	Chr.	Tps.	Inter.	Pre-Fin.	Tps	Fin.	Tps
1	Haaga Anton	S	KOSMIC / LKE	2	01'02"509"	1	1	01'02"446"	1	01'02"861"
2	Ticktum Daniel	GB	ZANARDI / PARILLA	10	01'02"684"	9	3	01'02"567"	2	01'02"957"
3	Ahmed Enaam	GB	FA KART / VORTEX	22	01'02"935"	23	18	01'02"562"	3	01'02"714"
4	Petrov Artem	RUS	DR / TM	6	01'02"638"	6	5	01'02"584"	4	01'02"965"
5	Defrancesco Devlin	USA	TONY KART / VORTEX	1	01'02"454"	2	30	01'02"870"	5	01'02"729"
6	Sargeant Logan	USA	FA KART / VORTEX	9	01'02"651"	3	2	01'02"585"	6	01'02"884"
7	Martinez Merono Eliseo	E	CRG / TM	47	01'03"336"	26	15	01'02"418"	7	01'02"828"
8	De Pauw Ulysse	B	KOSMIC / PARILLA	7	01'02"647"	10	P17	01'02"444"	8	01'02"677"
9	Beckmann David	D	TONY KART / PARILLA	3	01'02"580"	4	13	01'02"475"	9	01'03"047"
10	Martin Ross	GB	TONY KART / TM	23	01'02"945"	21	23	01'02"570"	10	01'02"720"
11	Lundgaard Christian	DK	TONY KART / VORTEX	12	01'02"746"	15	21	01'02"551"	11	01'02"842"
12	Martono Presley	RO	TONY KART / TM	32	01'03"056"	20	14	01'03"041"	12	01'03"141"
13	Lappalainen Konsta	FIN	TONY KART / VORTEX	30	01'03"027"	30	26	01'02"714"	13	01'03"046"
14	Leuliet Tom	F	BIREL / TM	40	01'03"199"	33	29	01'03"209"	14	01'03"658"
15	Lorandi Leonardo	I	TONY KART / TM	8	01'02"648"	18	34		15	01'03"092"
16	Floersch Sophia	D	FA KART / VORTEX	48	01'03"366"	28	22	01'02"928"	16	01'03"217"
17	Lindh Rasmus	B	PRAGA / PARILLA	14	01'02"805"	16	12	01'02"951"	17	01'03"373"
18	Roes Casper	DK	ENERGY / TM	34	01'03"154"	32	24	01'02"661"	18	01'03"198"
19	Maini Kush	IND	EXPRIT / VORTEX	31	01'03"053"	29	20	01'02"900"	19	01'03"237"
20	Garcia Lopez Marta	E	ZANARDI / PARILLA	16	01'02"869"	11	28	01'02"735"	20	01'02"862"
21	Travisanutto Lorenzo	I	PCR / TM	20	01'02"911"	12	33		21	01'02"999"
22	Baciуска Rokas	LT	ENERGY / TM	28	01'03"015"	31	25	01'02"695"	22	01'03"353"
23	Smith Joshua Francis	GB	ART GP / TM	25	01'02"980"	17	10	01'02"797"	23	01'03"471"
24	Vartanyan Alexander	RUS	TONY KART / VORTEX	4	01'02"604"	7	6	01'02"652"	24	01'02"843"
25	Mick Junior	D	TONY KART / VORTEX	11	01'02"742"	8	4	01'02"641"	25	01'02"892"
26	Pull James	GB	TONY KART / VORTEX	5	01'02"615"	14	8	01'02"700"	26	01'02"868"
27	Correa Juan	USA	ENERGY / TM	27	01'03"004"	13	7	01'02"790"	27	01'02"934"
28	Roosens Kenny	B	ZANARDI / TM	50	01'03"434"	39	27	01'02"790"	28	01'03"285"
29	Tontieri Paavo	FIN	ART GP / TM	18	01'02"892"	24	16	01'02"854"	29	01'03"520"
30	Azedo Sousa Yohan	P	ZANARDI / TM	42	01'03"250"	25	19	01'02"919"	30	01'03"272"
31	Fewtrell Max	GB	FA KART / VORTEX	21	01'02"915"	22	9	01'02"573"	31	01'02"883"
32	Moreira Laliberte Kami	CAN	TONY KART / TM	17	01'02"880"	27	31	01'04"934"	32	01'03"111"
33	Fernandez Wahbeh Sebastian	I	EXPRIT / VORTEX	29	01'03"026"	19	32	01'04"824"	33	01'14"022"
34	Lessennes Benjamin	B	KOSMIC / PARILLA	15	01'02"824"	5	11	01'02"377"	EX	
35	Drugovich Felipe	BRA	TONY KART / TM	26	01'02"988"	44				
36	Verkroost Bard	NL	FA KART / TM	46	01'03"333"	47				
37	Pasma Patrik	FIN	ART GP / TM	51	01'03"463"	48				
38	Pankiewicz Julia	PL	TONY KART / TM	38	01'03"182"	35				
39	Novalak Clement	CH	KOSMIC / VORTEX	35	01'03"172"	42				
40	Zotov Gleb	RUS	TONY KART / VORTEX	13	01'02"798"	38				
41	Lenzo Federico	I	LENZOKART / LKE	45	01'03"329"	49				
42	Reicher Simon	A	FA KART / VORTEX	53	01'03"587"	34				
43	Krencisz Jan	PL	KOSMIC / VORTEX	49	01'03"379"	53				
44	Alesi Giuliano	F	TONY KART / TM	33	01'03"065"	50				
45	Sario Robin	FIN	KOSMIC / VORTEX	44	01'03"271"	45				
46	Viscaal Bent	NL	ZANARDI / PARILLA	43	01'03"250"	55				
47	Lloveras Brunet Xavier	E	FA KART / VORTEX	41	01'03"249"	37				
48	Ye Yifei	CHN	ART GP / TM	55	01'03"868"	52				
49	Brozzoni Alessandro	F	ENERGY / TM	54	01'03"788"	54				
50	Yue Yang Sun	CHN	FA KART / VORTEX	37	01'03"182"	36				
51	Legeret Lucas	CH	ZANARDI / PARILLA	36	01'03"178"	43				
52	Tillet Archie	GB	CRG / TM	52	01'03"580"	51				
53	Konstantinos	GR	CRG / TM	24	01'02"970"	46				
54	Colombo Lorenzo	I	TONY KART / TM	19	01'02"895"	40				
55	Milesi Charles	F	TONY KART / PARILLA	39	01'03"196"	41				

KFJ ★ VEGA



## NATIONALY

ROYAUME-UNI	14	■
ITALIE	13	■
FINLANDE	11	■
FRANCE	9	■
FEDERATION DE RUSSIE	7	■
ALLEMAGNE	6	■
POLOGNE	6	■
BELGIQUE	5	■
SUEDE	5	■
ESPAGNE	5	■
DANEMARK	5	■
ETATS-UNIS	3	
PAYS-BAS	3	
CHINE	3	
INDE	2	
SUISSE	2	
ROUMANIE	2	
BRESIL	2	
AUTRICHE	1	
REPUBLIQUE TCHEQUE	1	
LITUANIE	1	
AFRIQUE DU SUD	1	
GRECE	1	
SINGAPOUR	1	
CANADA	1	
VENEZUELA	1	
PROVINCE CHINOISE DE TAIWAN	1	
PORTUGAL	1	
JAPON	1	

## CHASSIS

TONY KART	39	■
KOSMIC	14	■
ZANARDI	12	■
FA KART	12	■
ART GP	9	■
ENERGY	7	■
CRG	7	■
BIREL	5	■
TOP KART	2	
EXPRIT	2	
PRAGA	2	
PCR	1	
DR	1	
LENZOKART	1	

## ENGINES

TM	53	■
VORTEX	39	■
PARILLA	20	■
LKE	2	

## TIRES

DUNLOP	59	■
VEGA	55	■



**KS-5**  
 sparco®  
**KS-3**

LES NOUVELLES COMBINAISONS SPARCO  
**SPARCO KS-5 / SPARCO KS-3**  
 LES PREMIERES COMBINAISONS  
 A AVOIR ATTEINT LA NOUVELLE  
 H O M O L O G A T I O N  
**CIK-FIA N 2013-1**

**sparco®**

OFFICIAL SUPPLIER OF YOUR PASSION

s p a r c o . i t







# THREE DOUBLE WINNERS AT CASTELLETTO

WWW.RGMMC.COM

ROTAX MAX  
EURO CHALLENGE 2014  
ROUND 2 OF 4

ROTAX  
CASTELLETTO

By Frédéric Billet / © Photo KSP - Guillaume Veuve

## KEY POINTS OF THE WEEKEND

Date: May 26th to June 1st, 2014

Location: 7 Laghi International Circuit, Castelletto di Branduzzo, Italy - 1256 m

Entry: 167 drivers - 4 categories

- Great weather all week, despite the rain in the night on Friday night.
- Domination by the Austrian Preining, who won at Genk in Junior, in Senior the British driver Webb, and the Italian De Conto, unlucky in Belgium, in DD2.
- Preining increased his lead in the championship against Verschoor and MacDonald. Reilly and Brand are shoulder to shoulder in front of Öberg and Zhou in Senior. Cooper continues to lead DD2 ahead of Lennox-Lamb, Backman and Abbasse. Pierce shows his advantage in DD2 Masters against Morgado.



# PREINING, THE MAN TO BEAT IN JUNIOR

**T**homas Preining (FA Kart - Team TKP) dominated Rotax Junior, winning each phase of the competition. Max Timmermans (FA Kart - Dan Holland Racing) and Marcus Armstrong (FA Kart - Dan Holland Racing) tried to take the fight to him in qualifying and in the heats before Richard Verschoor (FA Kart - Team TKP) and Leonard Hoogenboom (FA Kart - Dan Holland Racing) took over the struggle in the prefinal. Verschoor followed in the footsteps of his teammate Preining for a second place finish, while Timmermans and Hoogenboom waged a very tight battle to the finish line for 3rd place. Timmermans clinched the podium position by 2 hundredths of a second.



# RETURN TO VICTORY FOR WEBB IN SENIOR

The end result in Rotax Senior did not reflect the intensity of the struggle between Guan Yu Zhou (Tony Kart - Strawberry Racing) and Harry Webb (Tony Kart - Strawberry Racing) throughout the weekend. The Chinese driver took pole position and conceded a second place in the heats. But the British driver took control on Saturday evening and didn't let go. The winner of the Prefinal ahead of Zhou and Joseph Reilly (Tony Kart - Strawberry

Racing), Webb won with ease while his two opponents crashed. Tom Grice (Tony Kart - Cole Racing) crossed the finish line in second position, but slipped back after a penalty and Pierce Lehane (FA Kart - Dan Holland Racing) who took the second step of the podium followed by Brett Ward (FA Kart - Dan Holland Racing).





## DD2 : DE CONTO IMPERIOUS AT HOME

Paolo De Conto (Birel - KMS Birel Motorsport) completed his success in Castelletto by taking every possible first place despite pressure from Sean Babington (Tony Kart - Strawberry Racing) and Jordon Lennox-Lamb (CRG - CRG).

Andreas Backman (Tony Kart - Strawberry Racing) unfortunately lost performance in the final. Anthony Abbasse (Sodi - Sodikart) dropped back in a heat after a battery problem but gradually undid the delay to finish second in the final

ahead of Ben Cooper (Birel - KMS Birel Motorsport). Cristiano Morgado (FA Kart - Dan Holland Racing) achieved a superb sixth overall in DD2 qualifying, but a big crash in the final left Martin Pierce (Praga -

Praga Kart Racing) to take the DD2 Masters victory.



## FRENCH DRIVERS IN THE RACE

Anthony Abbasse (Sodi - Sodikart) confirmed his position among the best in DD2 by taking the second step of the podium despite his holdup in the heats. Damien Vuillaume (Flandria - Flandria Kart Competition) confirmed his excellent performance by finishing 7th at Genk, Maxime Gravouille (Sodi - KPR) gained over 12 places in the final to finish 17th, while Julien Renaudin (Sodi - KPR) who was 4th in the Repechage, retired on the 2nd lap of the final. In DD2 Masters, Franck Rouxel (Sodi - Sodi Shop) and Guillaume Berteaux (Birel - Kartagene), although 26th in qualifying, could not reach the finals.

Xavier Pozzoli (Kosmic - Sonic Racing Kart) drove a magnificent race, moving up from 20th lap in qualifying to 5th place in the final. Vincent Fraisse (Sodi - Sodikart) started badly with 41st in qualifying, coming through the repechage and finishing 19th in the final. Up to 8th in the intermediate classification, Nicolas Picot (Sodi - KPR) stayed in the top 10 in the Prefinal, but retired after a collision at the start of the final. The other French drivers did not qualify.

Adrien Renaudin (Sodi - KPR), the only French driver qualified, was most successful in Junior with eight places gained and 13th position in the final.



RÉSULTS

INTERNATIONAL

P.	Pilote	Nat.	Mat.	Chr.	Tps.	Inter.	Pre-Fin.	Tps	Fin.	Tps
1	Preining Thomas	A	FA KART	1	49"871"	1	1	50"578"	1	50"675"
2	Verschoor Richard	B	FA KART	9	50"169"	12	P 2	50"675"	2	50"645"
3	Timmermans Max	B	TONY KART	3	50"007"	2	6	50"818"	3	50"670"
4	Hoogenboom Leonard	B	FA KART	30	50"346"	9	3	50"688"	4	50"764"
5	Macdonald Dean	GB	TONY KART	4	50"053"	13	4	50"625"	5	50"684"
6	Mccarthy Jack	GB	TONY KART	34	50"371"	7	11	50"861"	6	50"630"
7	Wooder Dave	GB	FA KART	8	50"143"	10	26	50"624"	7	50"458"
8	Armstrong Marcus	NZ	FA KART	2	50"004"	3	17	50"537"	8	50"669"
9	Keane Darren	USA	TONY KART	20	50"246"	11	9	50"715"	9	50"644"
10	Quinn Alex	GB	TONY KART	36	50"402"	15	7	50"602"	10	50"726"
11	Willemse Luc	NL	FA KART	5	50"074"	5	5	50"918"	11	50"588"
12	Hofer Max	A	BIREL	15	50"214"	16	13	50"684"	12	50"697"
13	Renaudin Adrien	F	SODIKART	29	50"345"	40	21	51"016"	13	51"028"
14	Mavlanov Denis	RUS	TBA	26	50"318"	23	8	50"414"	14	50"775"
15	Besler Berkay	TUR	KOSMIC	37	50"414"	35	19	50"810"	15	50"750"
16	Buys Dylan	NL	FA KART	23	50"285"	18	30	51"129"	16	50"876"
17	Minang Perdana	IDN	TONY KART	19	50"234"	27	14	50"777"	17	50"925"
18	Dunker Nick	NL	FA KART	35	50"375"	20	28	51"675"	18	50"844"
19	Schoell Nicolas	A	FA KART	31	50"348"	28	29	50"674"	19	50"714"
20	Gonzalez Javier	USA	KOSMIC	38	50"420"	19	18	51"072"	20	50"909"
21	Vips Juri	EST	TONY KART	16	50"216"	21	31	51"287"	21	50"825"
22	Van Kalmthout Rinus	B	FA KART	6	50"087"	6	25	50"592"	22	50"926"
23	Wishofer Mick	A	BIREL	14	50"213"	26	12	50"758"	23	51"097"
24	Brandt Yannik	CH	KOSMIC	46	50"618"	25	22	51"047"	24	51"028"
25	Simmons Ayrton	B	TONY KART	17	50"219"	31	27	51"668"	25	50"895"
26	Brito Enrique	ECU	CRG	7	50"140"	14	33		P 26	50"723"
27	Slavinski Dzianis	BLR	TONY KART	10	50"191"	8	10	50"640"	P 27	51"010"
28	Brown Nutley Jordan	GB	TONY KART	27	50"322"	33	P 24	50"675"	28	51"257"
29	Bentley-ellis Hugo	GB	KOSMIC	18	50"231"	32	16	50"669"	P 29	51"177"
30	Wragg Kieran	GB	TONY KART	32	50"356"	34	23	51"026"	30	51"215"
31	Fulk Zak	GB	TONY KART	28	50"336"	17	P 34		31	50"660"
32	Kroes Danny	NL	TONY KART	22	50"274"	24	20	50"841"	32	50"898"
33	Van Der Laan Mauricio	E	INTREPID	13	50"208"	4	32		P 33	50"911"
34	Hutchison Finlay	GB	KOSMIC	24	50"287"	22	15	50"797"	34	
35	Zhuo Cao	CHN	FA KART	39	50"449"	41				
36	Keskitalo Aleks	FIN	FA KART	48	50"631"	47				
37	Simmenauer Jean Baptiste	F	TONY KART	11	50"196"	37				
38	Olofsen Lars	B	TONY KART	42	50"500"	50				
39	De Rooij Denise	NL	TONY KART	33	50"364"	30				
40	Perceval Antoine	F	TONY KART	50	50"705"	39				
41	Mccarthy Michael	USA	BIREL	43	50"544"	51				
42	Solarczyk Matthew	USA	BIREL	40	50"461"	44				
43	Simmenauer Louis Ferdinand	F	TONY KART	25	50"311"	43				
44	Bezel Jakub	CZ	MS KART	45	50"597"	45				
45	Chany Christopher	F	ARROW	53	51"196"	49				
46	Slosar Jan	SVN	ENERGY	51	50"944"	54				
47	Stanley Micah	F	ARROW	57	51"697"	55				
48	Caouette Jakeson	F	ARROW	56	51"468"	57				
49	Rasmussen Oliver	F	ARROW	55	51"400"	56				
50	Kuznetcov Gleb	RUS	CRG	54	51"234"	46				
51	Real Del Sarte Ruben	NL	FA KART	49	50"702"	48				
52	Mazzaferro Gianfranco	CAN	FA KART	12	50"204"	38				
53	Louko Daniel	FIN	TONY KART	21	50"247"	42				
54	Keel Aidan	USA	BIREL	41	50"464"	29				
55	Sarfati Jean Noel	F	TONY KART	52	51"011"	36				
56	Cohen Ido	ISR	TONY KART	47	50"619"	53				
57	Apotheloz Julien	CH	KOSMIC	44	50"593"	52				

ROTAX JUNIOR

P.	Pilote	Nat.	Mat.	Chr.	Tps.	Inter.	Pre-Fin.	Tps	Fin.	Tps
1	Webb Harry	GB	TONY KART	2	48"968"	1	1	49"327"	1	49"645"
2	Lehane Pierce	AUS	FA KART	8	49"294"	5	4	49"461"	2	49"824"
3	Ward Brett	GB	FA KART	3	49"074"	6	5	49"373"	3	49"818"
4	Varley Luke	GB	BIREL	30	49"530"	13	11	49"770"	4	49"899"
5	Pozzoli Xavier	F	KOSMIC	20	49"484"	11	8	49"635"	5	49"905"
6	Grice Tom	GB	TONY KART	32	49"535"	14	12	49"536"	P 6	49"924"
7	Oberg Victor	S	GILLARD	34	49"550"	20	14	49"590"	7	49"906"
8	Smelt Sam	GB	KOSMIC	46	49"782"	27	26	49"996"	8	50"013"
9	Rupp Glenn	D	TONY KART	36	49"575"	28	24	49"832"	9	50"007"
10	Turner Charlie	GB	TONY KART	22	49"492"	29	23	49"911"	10	50"049"
11	Talvar Aavo	EST	TONY KART	21	49"486"	12	31	49"762"	11	49"782"
12	Brand Edward	GB	INTREPID	5	49"176"	4	6	49"462"	P 12	50"019"
13	Bailey Benjamin	B	TONY KART	39	49"644"	25	P 29	49"983"	13	49"927"
14	Van Parijs Glenn	B	TONY KART	25	49"499"	23	16	49"697"	14	49"934"
15	Pispanen Ilari	FIN	BIREL	15	49"401"	19	21	49"828"	15	49"981"
16	De Melo Claman Zachary	CAN	INTREPID	12	49"367"	18	13	49"653"	P 16	49"840"
17	Mortensen Martin	DK	TONY KART	10	49"345"	7	15	49"860"	17	49"991"
18	Bezel Petr	CZ	MS KART	37	49"578"	24	25	50"070"	18	50"134"
19	Fraisse Vincent	F	SODIKART	41	49"701"	35	19	49"914"	19	50"239"
20	De Brabander Yannick	B	CRG	33	49"543"	26	32	50"200"	20	49"976"
21	Reilly Joseph	GB	TONY KART	4	49"114"	3	3	49"388"	21	49"780"
22	Vollstedt Philip	DK	TONY KART	9	49"327"	21	30	49"694"	22	49"979"
23	White Josh	GB	TONY KART	18	49"469"	10	9	49"545"	23	50"253"
24	Yuto Tsujii	J	FA KART	23	49"495"	22	27	49"933"	24	49"974"
25	Knott Luke	GB	TONY KART	17	49"469"	34	20	49"615"	25	50"071"
26	Lamborelle Lars	NL	TONY KART	7	49"275"	15	7	49"641"	P 26	49"758"
27	Schoell Constantin	A	FA KART	14	49"394"	32	22	49"829"	27	50"060"
28	Bartoszuk Lukasz	PL	CRG	11	49"349"	9	17	49"875"	28	50"251"
29	Zhou Guan Yu	CHN	TONY KART	1	48"927"	2	2	49"350"	P 29	49"722"
30	Trombelli Alessandro	I	TBA	27	49"504"	33	P 28	49"737"	30	52"331"
31	Tansley Edward	GB	TONY KART	13	49"383"	16	18	49"705"	P 31	51"146"
32	Picot Nicolas	F	SODIKART	19	49"480"	8	10	49"833"	32	
33	Myers Oliver	GB	TONY KART	28	49"509"	31	EX			
34	Vanthoor Dries	B	FA KART	6	49"274"	17	EX			
35	Deckers Yaro	B	FA KART	43	49"720"	44				
36	Fotia Anthony	F	SODIKART	48	49"788"	39				
37	Pykalainen Juuso	FIN	TONY KART	45	49"770"	38				
38	Al Rawahi Abdullah	OMN	DR	40	49"673"	46				
39	Renberg Max	S	TONY KART	59	50"220"	47				
40	Loft Christian	DK	TONY KART	54	49"979"	43				
41	Mazzantini Marco	I	RIGHETTI RIDOLFI	44	49"721"	37				
42	Cool Michael	B	TONY KART	42	49"713"	36				
43	Constable Jack	GB	TONY KART	52	49"900"	45				
44	Shchekochikhin Petr	RUS	KOSMIC	62	50"328"	57				
45	Falchero Julien	F	KOSMIC	29	49"526"	40				
46	Shtotland Maksim	RUS	FA KART	26	49"502"	61				
47	Rossi Mirco	SMR	HAASE	57	50"065"	51				
48	Ptak Antoni	USA	BIREL	51	49"888"	49				
49	Laurent Maxence	F	FLANDRIA KART	60	50"264"	59				
50	Balbo Natalia	I	ZANARDI	50	49"850"	56				
51	Laghi Filippo	I	HAASE	38	49"602"	41				
52	Malandrinos Angelos	GR	TONY KART	56	50"052"	53				
53	Bakken Marie	N	GILLARD	55	49"986"	52				
54	Martini Cecile	F	SODIKART	61	50"275"	50				
55	Schmitt Maximilian	D	PRAGA	53	49"907"	48				
56	Jonk Gavin	NL	GILLARD	47	49"785"	58				
57	Meijer Tom	NL	TONY KART	35	49"569"	30				
58	Backman Jessica	S	TONY KART	16	49"413"	42				
59	Artner Stefan	A	TONY KART	DQ		54				
60	Price Josh	GB	ART GP	24	49"498"	55				
61	Leskela Jaakko	FIN	BIREL	49	49"841"	60				
62	Hermouet Julien	F	LENZOKART	31	49"530"	62				
63	Gobbi Christian	I	SODI	58	50"179"	63				

ROTAX SENIOR



P.	Pilote	Nat.	Mat.	Chr.	Tps.	Inter.	Pre-Fin.	Tps	Fin.	Tps
1	De Conto Paolo	I	BIREL	1	48"046"	1	1	48"467"	1	48"346"
2	Abbas Anthony	F	SODIKART	3	48"075"	14	6	48"519"	2	48"362"
3	Cooper Ben	CAN	BIREL	7	48"273"	5	4	48"478"	3	48"412"
4	Babington Sean	GB	TONY KART	2	48"068"	2	2	48"595"	4	48"475"
5	Lennox Lamb Jordon	GB	CRG	4	48"107"	3	3	48"579"	5	48"446"
6	Backman Andreas	S	TONY KART	6	48"242"	4	5	48"686"	6	48"496"
7	Vuillaume Damien	F	FLANDRIA KART	8	48"289"	12	10	48"646"	7	48"506"
8	Collings Joshua	GB	CRG	9	48"296"	21	12	48"584"	8	48"541"
9	Christiansen Michael E	DK	TONY KART	11	48"378"	6	7	48"763"	9	48"420"
10	De Ruwe Xen	B	ART GP	13	48"395"	19	13	48"813"	10	48"734"
11	Eerden Bryan	NL	CRG	19	48"539"	22	14	48"829"	11	48"685"
12	Kancsar Ferenc	H	BIREL	20	48"554"	11	9	48"748"	12	48"686"
13	Santoro Dario	CH	MARANELLO	12	48"386"	13	21	48"932"	13	48"587"
14	Formal Daniel	USA	CRG	18	48"531"	8	8	48"860"	14	48"666"
15	Rotar David	I	INTREPID	31	48"829"	27	16	48"816"	15	48"994"
16	Schirmer Marcel	D	TONY KART	25	48"683"	30	19	49"069"	16	49"027"
17	Gravouille Maxime	F	SODIKART	28	48"725"	24	P 29	49"064"	17	48"732"
18	Sessa Ennio	I	ART GP	21	48"563"	31	24	48"989"	18	48"854"
19	Curto Alessio	D	CRG	DQ		26	22	48"886"	19	48"585"
20	Pullinger Barrie	GB	FA KART	26	48"711"	18	26	49"007"	20	48"613"
21	Laiho Miika	FIN	HAASE	24	48"660"	17	30	51"625"	21	48"999"
22	Montfoort Erwin	NL	KOSMIC	32	48"841"	23	25	49"024"	22	48"955"
23	Apotheloz Cyril	CH	KOSMIC	27	48"721"	28	28	49"707"	23	49"208"
24	Ludi Kevin	CH	KOSMIC	15	48"458"	9	31	50"832"	24	48"654"
25	Van Riet Lorenzo	NL	FORMULA K	17	48"522"	25	20	48"846"	25	48"787"
26	Beggi Alex	I	BIREL	5	48"158"	15	17	48"750"	P 26	48"496"
27	Fleischmann Maxi	D	PRAGA	14	48"420"	10	15	48"889"	P 27	59"283"
28	Renaudin Julien	F	SODIKART	33	48"846"	33	27	49"288"	28	54"031"
29	Kalesis Filippos	GR	DR	22	48"579"	20	11	48"493"	29	
30	Kamali Luka	D	CRG	10	48"312"	7	32		30	
31	Steinerts Martins	LV	MS KART	23	48"631"	29	23	49"011"	EX	
32	Aceto Massimo	I	RIGHETTI RIDOLFI	16	48"508"	16	18	48"947"	EX	
33	Baptista Henrique	P	FA KART	34	48"850"	32				
34	Bizzotto Alessandro	CAN	CRG	30	48"796"	35				
35	Seewer Philipp	CH	KOSMIC	NQ		34				
36	Pyttiik Tom	GB	FA KART	35	49"209"	38				
37	Kolarov Vasil	BG	CRG	DQ		37				
38	Al Rawahi Sanad	OMN	DR	29	48"745"	36				

DD2

P.	Pilote	Nat.	Mat.	Chr.	Tps.	Inter.	Pre-Fin.	Tps	Fin.	Tps
1	Pierce Martin	GB	PRAGA	4	48"844"	2	1	49"036"	1	49"041"
2	Morgado Cristiano	ZA	FA KART	1	48"211"	1	P 2	50"755"	2	48"808"
3	Adams Christophe	F	KOSMIC	3	48"805"	3				
4	Germain Tamsin	GB	GILLARD	5	49"073"	8				
5	Rouxel Franck	F	SODIKART	9	01"20"940"	7				
6	Winzen Lothar	CH	ZANARDI	8	50"133"	6				
7	Timaks Uldis	LV	MS KART	7	49"672"	9				
8	Lambert Florent	GB	TONY KART	6	49"124"	4				
9	Berteaux Guillaume	F	BIREL	2	48"674"	5				

DD2 MASTER

## NATIONALY

ROYAUME-UNI	31	■
FRANCE	24	■
BELGIQUE	13	■
PAYS-BAS	12	■
ITALIE	10	■
SUISSE	7	■
ETATS-UNIS	7	■
AUTRICHE	6	■
FINLANDE	6	■
ALLEMAGNE	6	■
SUEDE	4	■
CANADA	4	■
DANEMARK	4	■
FEDERATION DE RUSSIE	4	■
CHINE	2	■
GRECE	2	■
LETTONIE	2	■
OMAN	2	■
ESTONIE	2	■
REPUBLIQUE TCHEQUE	2	■
ESPAGNE	1	■
PORTUGAL	1	■
SAINT-MARIN	1	■
SLOVENIE	1	■
BELARUS	1	■
BULGARIE	1	■
POLOGNE	1	■
TURQUIE	1	■
INDONESIE	1	■
JAPON	1	■
EQUATEUR	1	■
ISRAËL	1	■
HONGRIE	1	■
NORVEGE	1	■
NOUVELLE-ZELANDE	1	■
AUSTRALIE	1	■
AFRIQUE DU SUD	1	■

## CHASSIS

TONY KART	51	■
FA KART	25	■
KOSMIC	15	■
BIREL	14	■
CRG	12	■
SODI	10	■
INTREPID	4	■
GILLARD	4	■
MS KART	4	■
ARROW	4	■
HAASE	3	■
DR	3	■
PRAGA	3	■
ART GP	3	■
ZANARDI	2	■
TBA	2	■
RIGHETTI RIDOLFI	2	■
FLANDRIA KART	2	■
MARANELLO	1	■
ENERGY	1	■
LENZOKART	1	■
FORMULA K	1	■



# TECPRO

# BARRIERS



[www.tecprobarriers.com](http://www.tecprobarriers.com)

TECPRO BARRIERS Tel: +33 (0) 609 534 538 Email: [rafael@tecpro.fr](mailto:rafael@tecpro.fr)





# FRENCH CUP FOR KZ 125 & KZ 125 GENTLEMAN LE MANS

By Frédéric Billet / © Photo KSP - Philippe Kalmès

## FIRST AT LE MANS FOR LAURENT AND BOISNARD

### KEY POINTS OF THE WEEKEND

Date: 3rd and 4th May 2014

Location: Le Mans Circuit International - 1368 m - anti-clockwise

First event at the new FFSA Le Mans

Entry: 57 KZ 125, 38 KZ 125 Gentleman (over 32 years)

Winners: Thomas Laurent (Tony Kart / Vortex) and Erwan Boisnard (FA Kart / Vortex).

→ Excellent result for the Cédric Sport team, with two wins in KZ 125 and four in Gentleman.



The weather Saturday and Sunday at Le Mans was beautiful, although it was not easy to take the lead.

The first successful implementation of the FFSA Regulation replacing parc ferme tyres with control using the MiniRAE Lite and control fuel from a petrol station, checked throughout the weekend.

Excellent reaction to the new Vega SL4 tyres, with efficiency and durability.

# FIAULT DOMINATES KZ 125 UNTIL PREFINAL, BUT LAURENT WINS THE CUP

Everything had worked out for Charles Fiault (Sodi / Parilla), from pole to victory in the prefinal after the qualifying heats, but he missed out in the final in favour of the driver tipped for the result, the young Thomas Laurent (Tony Kart / Vortex), followed by Maxime Roy (Tony Kart / Vortex). Positions in the top three did not change throughout the 22 laps of the final.



*"The beginning of the meeting was not easy!" Thomas Laurent said. "It was not very good, for both the chassis and the engine. I was 6th in qualifying. But the Cedric Sport team worked well and I was able to move up to just behind Charles (Fiault) in the heats. I stayed second in the prefinal and I knew everything would play out the final. Then Maxime (Roy) and Charles were back with me in the last few laps. I did everything not to stress and I continued to race as I had done before, without defending, and that's how I won!"*



# BOISNARD TAKES THE KZ 125 GENTLEMAN CUP AFTER A LONG DUEL WITH GROSSO

Emilien Grosso (Tony Kart / Vortex) and Erwan Boisnard (FA Kart / Vortex) continued to battle throughout the weekend. Again, the start of the final was crucial. "After a successful start, the bulk of the work was to stay far enough ahead to prevent Emilien (Grosso) attempting an attack. We had left a little to spare on a mechanical level to stay at the front in the final and it helped me a lot," explained Boisnard with the Cup in hand.

At 35, Erwan Boisnard has several important successes to his credit, including the French KZ 125 Championship in 2011 at Salbris and the Vice-Championship in 2012 in Mirecourt.



By Frédéric Billet / © Photo KSP - Philippe Kalmès

FRENCH CUP KZ - LE MANS

# CÉDRIC SPORT HAS THE WIND IN ITS SAILS

A renowned driver and a recognized professional for many years, Cédric Goudant embarked on the adventure of creating his own racing team in early 2009 in a surprising place that lives with the rhythm of motorsport, Lohéac village in Brittany. Faithful to the Tony Kart chassis since his collaboration with Alain Colin and RKO Angerville, Cedric has, besides his race facilities, new premises at Lohéac after the fire that destroyed the building at the kart track in May 2012 .

Cedric Sport once again found themselves in the spotlight at the French KZ 125 Cup held in early May at Le Mans. With a double in KZ 125 with Thomas Laurent and Maxime Roy, a winning quartet in KZ 125 Gentleman with Erwan Boissard, Emilien Grosso, Franck Savouret and Jerome Lardenais, the celebration was full of atmosphere in the Cédric Sport tent!

For Cédric Goudant, there is no secret to winning: "The only thing that matters is the work! We have many different customers and we must provide the best equipment for their needs. It is true that we spend a lot of time in preparation in the workshop, it's 7 days 7 for 9 months of the year. Everything must be perfect for racing and it takes a lot of effort, but it's what we like to do! When victory doesn't come, we don't look for an apology from the tyres, our opponents, the weather... more work is needed, that's all. Tec-Sav has forced us to become even more serious, more professional, and I thank them."



In KZ, Cedric began with TM before moving to Vortex in 2013. "Everyone used TMs, so we were trying to find a difference. Our collaboration with the Vortex factory, and Mr. Robazzi, is excellent. He is a true enthusiast who follows what we do closely. Initially, I learned everything with Olivier Liegeois at my side. With the test bench we could understand the Vortex and find out how to win. That's a lot of investment, but it is a choice I do not regret."

Cédric Sport is not confined to KZ, all classes have their place in the team, from Minime to Rotax, for whom the company is an authorized service center.

"We work on data acquisition from Minime onwards. This is very useful for drivers, whatever their level. We manage two telemetry systems during races and all our customers have access."

In addition to the races in France, Cédric Sport is now preparing to assist the drivers with the European KZ2 Championship with Maxime Roy, the French Champion, and Thomas Laurent, a driver who is moving to the forefront of the competition.

[CEDRIC-SPORT.COM](http://CEDRIC-SPORT.COM)

CÉDRIC GOUTANT  
 85  
 PASO





P.	Pilote	Nat.	Mat.	Chr.	Tps.	Inter.	Pre-Fin	Tps	Coupe CRK	Tps	Fin	Tps
1	Laurent Thomas	F	TONY KART / VORTEX	6	51"275"	2	2	51"658"			1	51"804"
2	Roy Maxime	F	OTK / VORTEX	9	51"400"	4	4	51"841"			2	51"717"
3	Fiault Charles	F	SODI / PARILLA	1	50"968"	1	1	51"766"			3	51"766"
4	Da Silva Clement	F	BIREL / TM	3	51"121"	15	15	51"936"			4	51"776"
5	Mich Thomas	F	BIREL / TM	7	51"377"	11	7	51"849"			5	51"956"
6	Le Brigand Julien	F	CRG / MAXTER	13	51"507"	12	3	51"825"			6	51"987"
7	Loubere Pierre	F	SODI / TM	4	51"145"	6	5	51"749"			7	51"975"
8	Letailleur Thomas	F	MIRAGE / TM	11	51"469"	3	6	51"848"			8	52"014"
9	Goupy Julien	F	PRAGA / APRILIA	12	51"472"	19	14	51"965"			9	52"026"
10	Renaux Johan	F	CRG / PARILLA	10	51"405"	7	16	51"759"			10	52"062"
11	Bourgeois Pierre	F	ART GP / TM	33	52"039"	28	17	51"970"			11	52"052"
12	Poulain Antoine	F	SODI / TM	18	51"682"	5	8	51"938"			12	52"195"
13	David Paul	F	TONY KART / MODENA	19	51"762"	8	13	52"130"			13	52"369"
14	Poncelet Julien	F	TONY KART / VORTEX	21	51"792"	25	32	52"091"			14	52"202"
15	Magnin Charles	F	TONY KART / TM	15	51"561"	23	20	52"287"			15	52"239"
16	Maatougui Adam	F	ENERGY / TM	41	52"188"	24	19	52"159"			16	52"136"
17	Gonnachon Vincent	F	TONY KART / MODENA	14	51"527"	20	23	52"172"			17	52"147"
18	Ramon Eric	F	INTREPID / MODENA	16	51"617"	14	10	51"933"			18	51"933"
19	Leglise David	F	TONY KART / TM	17	51"651"	16	P 18	52"134"			19	52"350"
20	Ramon Jordan	F	MBA / TM	26	51"877"	17	29	52"370"			20	52"216"
21	Ponsart Matthieu	F	KOSMIC / PARILLA	30	51"994"	34	24	52"186"			21	52"321"
22	Briet Franck	F	ART GP / TM	35	52"080"	35	22	51"947"			22	51"871"
23	Guibbert Enzo	F	CRG / PARILLA	2	51"097"	29	37				23	51"937"
24	Godard Ludovic	F	FA KART / MODENA	20	51"784"	10	9	51"866"			24	52"124"
25	Vallois Julien	F	TONY KART / TM	29	51"981"	21	26	52"042"			25	52"043"
26	Bloyet Adrien	F	TONY KART / VORTEX	23	51"825"	32	38				26	52"077"
27	Josse Teddy	F	CRG / MAXTER	31	52"017"	33	25	52"064"			27	52"258"
28	Soler Etienne	F	SODI / MODENA	52	52"710"	38	31	52"709"			28	52"776"
29	Luisier Simon	F	ENERGY / PARILLA	36	52"095"	39	27	52"211"			29	52"200"
30	Choisnet Hugo	F	BIREL / TM	45	52"273"	37	30	52"603"			30	52"608"
31	Weber Morgan	F	CRG / MAXTER	55		18	11	51"595"			31	51"829"
32	Vair Xavier	F	ART GP / TM	38	52"139"	22	33	52"476"			32	52"455"
33	Ucci Giovanni	F	TONY KART / MODENA	24	51"840"	27	36	52"536"			33	52"047"
34	Rohrbasser Nicolas	F	ART GP / TM	8	51"383"	9	12	51"977"			34	52"222"
35	Jamin Geoffrey	F	TONY KART / VORTEX	5	51"229"	31	34	52"280"			35	52"401"
36	Luisier Sebastien	F	ENERGY / PARILLA	27	51"932"	13	35	52"397"			36	52"274"
37	Tissot Alexandre	F	PCR / TM	32	52"030"	26	21	52"244"			37	
38	Morel Benoit	F	CRG / TM	34	52"078"	30	28	52"256"			38	
39	Bondier Nelson	F	FORMULA K / PARILLA	56		36	39				39	
40	Aubry Ivan	F	ART GP / TM	43	52"198"	41			1	52"940"		
41	Krypciak Pierre	F	ALPHA KARTING / TM	42	52"197"	45			2	52"643"		
42	Hemery Thomas	F	CRG / TM	22	51"805"	43			3	52"992"		
43	Nussbaum Arnaud	F	ART GP / TM	25	51"844"	49			4	52"844"		
44	Creniault Vincent	F	TONY KART / TM	51	52"557"	46			5	52"888"		
45	Coursault Alexis	F	BIREL / TM	40	52"181"	44			6	52"545"		
46	Vetu Guillaume	F	FA KART / VORTEX	50	52"370"	53			7	52"922"		
47	Hellaouet Sebastien	F	LH / MAXTER	48	52"292"	42			8	53"052"		
48	Dussart Mike	F	CRG / VORTEX	53	52"812"	50			9	53"395"		
49	Farinaccio Anthony	F	SODI / TM	44	52"235"	55			10	53"314"		
50	Caillias Jean Baptiste	F	MERLIN / SGM	54	52"937"	52			11	53"278"		
51	Coldefy Jason	F	BIREL / TM	47	52"279"	47			12	53"143"		
52	Cardoso Marcio	F	BIREL / TM	37	52"119"	40			13	53"068"		
53	Roseo Arnaud	F	SODI / MAXTER	39	52"177"	51			14	53"419"		
54	Dreau Silann	F	CRG / MAXTER	28	51"972"	48			15			
55	Barbotte Jeremy	F	INTREPID / MODENA	46	52"276"	54			16			
56	Nuvolini Stephen	F	OK1 / PARILLA	57								
57	Pizzardo Nicolas	F	FA KART / VORTEX	49	52"367"	EXCLU MANIFESTATION						

KZ125 ★ VEGA

P.	Pilote	Nat.	Mat.	Chr.	Tps.	Inter.	Pre-Fin.	Tps	Fin.	Tps
1	Boisnard Erwan	F	TONY KART / VORTEX	2	52"106"	1	2	52"586"	1	52"238"
2	Grosso Emilien	F	TONY KART / VORTEX	1	51"920"	2	1	52"505"	2	52"396"
3	Savouret Franck	F	FA KART / VORTEX	3	52"112"	4	3	52"462"	3	52"616"
4	Lardenais Jerome	F	TONY KART / TM	9	52"424"	8	4	52"760"	4	52"522"
5	Launay Aurore	F	SODI / TM	6	52"235"	5	6	52"594"	5	52"527"
6	Galichon Emmanuel	F	INTREPID / MODENA	7	52"310"	6	7	52"715"	6	52"683"
7	Benabent Bruno	F	BIREL / TM	13	52"532"	16	8	52"435"	7	52"597"
8	Girardet Jean Pierre	F	SODI / TM	15	52"578"	9	9	52"950"	8	52"885"
9	Robillot Arnaud	F	TONY KART / MODENA	10	52"495"	11	11	52"774"	9	52"629"
10	Bailly Armand	F	TONY KART / MODENA	11	52"504"	17	14	52"690"	10	52"844"
11	Brucoli Enzo	F	TONY KART / TM	16	52"615"	22	16	53"043"	11	52"799"
12	Berteaux Marc	F	BIREL / TM	20	52"754"	18	13	52"922"	12	53"014"
13	Deharte Julien	F	CRG / VORTEX	12	52"520"	13	19	53"278"	13	52"873"
14	Tardivot Ludovic	F	TONY KART / VORTEX	25	52"956"	28	26	53"203"	14	53"278"
15	Girardet Mickael	F	MERLIN / TM	28	53"066"	33	24	53"134"	15	53"197"
16	Dziadus Laurent	F	ALPHA KARTING / TM	29	53"244"	23	18	53"282"	16	53"235"
17	Portmann Benoita	F	INTREPID / TM	22	52"886"	19	20	53"066"	17	53"130"
18	Clemencon Nicolas	F	TOP KART / TM	35	53"774"	31	27	53"436"	18	53"659"
19	Galmiche Olivier	F	TONY KART / PARILLA	31	53"277"	32	28	53"510"	19	53"508"
20	Schlichting Patrick	F	WILDKART / TM	36	54"597"	36	31	54"187"	20	54"458"
21	Lelievre Geoffroy	F	ENERGY / MODENA	18	52"701"	20	17	53"162"	21	52"998"
22	Delaunay Nicolas	F	ALPHA KARTING / TM	24	52"937"	25	33	53"459"	22	53"723"
23	Soares Eric	F	SODI / TM	33	53"543"	37	35	54"105"	23	54"746"
24	Kussmaul Jean Francois	F	TECNO / TM	14	52"548"	12	15	52"742"	24	52"967"
25	Preuvost Erick	F	OK1 / PARILLA	27	53"043"	27	32	53"400"	25	53"640"
26	Cesareo Bruno	F	BIREL / TM	37	55"105"	35	30	54"469"	P 26	54"640"
27	Fighiera Thierry	F	MIRAGE / TM	21	52"754"	21	22	53"034"	27	53"722"
28	Vits Alexandre	F	DR / TM	38	01'00"800"	29	21	53"119"	28	54"145"
29	Capietto Guillaume	F	ART GP / TM	8	52"369"	7	5	52"573"	29	55"308"
30	Legendre Teddy	F	TONY KART / TM	19	52"736"	15	10	52"676"	30	55"478"
31	Pianet Brice	F	SODI / TM	17	52"643"	14	12	52"787"	31	59"213"
32	Planchon Olivier	F	BIREL / TM	23	52"920"	24	23	53"063"	32	
33	Weissen Laurent	F	SODI / TM	26	53"016"	26	25	53"249"	33	
34	Lefebvre Frederic	F	CRG / VORTEX	34	53"578"	30	29	53"710"	34	
35	Spirgel Cedric	F	BIREL / TM	4	52"206"	3	36	53"147"	35	
36	Bailly Thomas	F	TONY KART / MODENA	5	52"229"	10	34	53"132"	36	
37	Raccamier Thierry	F	BIREL / PARILLA	32	53"305"	38	37			
38	Chedhomme Sebastien	F	KOSMIC / TM	30	53"251"	34	38			

KZ125 GENTLEMAN ★ VEGA









## NATIONALY

FRANCE 95 

## CHASSIS

TONY KART	21	
BIREL	12	
SODI	11	
CRG	11	
ART GP	7	
INTREPID	4	
ENERGY	4	
FA KART	4	
ALPHA KARTING	3	
KOSMIC	2	
MERLIN	2	
MIRAGE	2	
OKI	2	
MBA	1	
TECNO	1	
PCR	1	
TOP KART	1	
DR	1	
LH	1	
PRAGA	1	
OTK	1	
WILDKART	1	
FORMULA K	1	

## ENGINES

TM	50	
VORTEX	14	
MODENA	12	
PARILLA	11	
MAXTER	6	
SGM	1	
APRILIA	1	

## TIRES

VEGA 95 



**TIGER Black**  
**KF - FRM version**  
**KZ version**

**Made for podiums !**

[www.alpha-karting.fr](http://www.alpha-karting.fr) 



Alpha competition range :



Bambino - Mini-Kart - Minime - Cadet - Nationale - X30 Junior - X30 Senior - Rotax Max - X30 Super Shifter - KZ125 - KZ2

 **Victories and podiums in all catégories**



# FFSA SUPERKART LEDENON

Info & © Photo MEDIASUPERKART



**FFSA**  
CHAMPIONNAT  
DE FRANCE **SUPERKART**

The final allowed the three fired up drivers to compete again. It was a great show at all levels. Aebischer made a good start, and Sébastia had not expected to take the lead, but Elkmann spun on the formation lap and was trying to get through the traffic to focus on Aebischer. Sébastia had a reinvigorated frame, he escaped and set a new track record (1'18" 687"). The German concentrated and late in the race attacked the Swiss driver. Goullancourt and Gerber passed at each corner, allowing to Busby close on them and grab 4th place. Another well positioned Rookie was M.Taloc in 7th. Sebastia had an excellent meeting with two wins and three podiums, but the championship leader is now P.Elkmann which should encourage them all to compete in the full championship, which was not what they originally planned.

## RECORDS BROKEN & A BIG HEART

The French Superkart Championship continued its tour of the country at Ledenon (2nd round) with three races on the programme run in summer heat.

Three drivers dominated the racing and set a record pace: the German Peter Elkmann on an MS kart with a VM engine with the Dutch team Karting Paradise, the transformed Swiss driver Etienne Aebischer (PVP / FPE) and the French

driver Alexandre Sebastia (Anderson / FPE) who was on his favourite track where he won two races. From qualifying, the tone was set, with P.Elkmann beating the track record in Superkart when he passed under the checkered flag in the final seconds with 1'19"687".

In race 1, the three protagonists went ahead of the entire pack with impressive braking. Elkmann then showed how it takes a "big heart" to take the Ledenon

triple blind left after the start. The trio raced man to man, sometimes Aebischer, sometimes Sébastia in command. Cyril Vayssié was the only one to keep pace, but then dropped back two seconds. He never managed to regain those few metres. Behind them, not to be outdone, were the two Britons C. Kinsey and K. Busby, loyal to the Championship, delivered an uncertain duel. However they were joined by J.Goullancourt who was motivated by his acquisition of a DEA Motor, and P

. Gerber, another Swiss driver, who had to retire with a small problem. Elkmann took the lead before the halfway point and began to outpace both opponents who were still fighting. Aebischer kept the advantage against Sebastia. The hilly circuit in Cévennes is very physical, and drivers were exhausted at the end of the race. Fatigue was especially hard on drivers during the first race, and Goullancourt finished in 4th ahead of the dashing British duo because Vayssié

wobbled at the end of the race.

The second race was less pugnacious as there were many retirements. It came down to a restricted duel as Aebischer retired at the start with a broken chain. However Sebastia took his revenge, he had changed parts in his engine and he who finally got the measure of the German. A clash between Vayssié and Goullancourt eliminated Goullancourt, but later, although he moved back up

the hierarchy, Vayssié broke down again. Gerber drove consistently and was happy to get on the podium by a narrow margin, a position he saved with the help of the red flag, deployed for safety within two laps, while Busby dropped back. The 2014 field includes several Rookies who have done well. M. Oliveira took the virtual cup for coming top (7th and 5th) for the second consecutive time. The last entry, A. Joubert, twice finished in the top ten in his first meeting.



## RESULTS

## STATISTICS

P.	Pilote	Nat.	Mat.	Chr 1	Chr 2	Course 1	Course 2	Course 3
1	Elkmann Peter	D	MSKART / VM	1	01'19"183"	1	01'19"183"	01'20"384"
2	Sebastia Alexandre	F	ANDERSON / FPE	3	01'20"026"	3	01'20"026"	01'20"675"
3	Busby Kevin	GB	ANDERSON / FPE	5	01'21"877"	5	01'21"877"	01'23"265"
4	Aebischer Etienne	CH	PVP / FPE	2	01'19"580"	2	01'19"580"	01'21"015"
5	Goullancourt Julien	F	ANDERSON / PVP	4	01'21"564"	4	01'21"564"	01'21"854"
6	Gerber Philippe	CH	PVP / FPE	6	01'22"482"	6	01'22"482"	01'23"127"
7	Vayssie Cyril	F	PVP / DEA	14	01'26"476"	7	01'23"195"	01'21"216"
8	Focque Pierre	F	PVP / FPE	10	01'25"559"	12	01'25"559"	01'26"187"
9	Oliveira Mario	P	PVP / FPE	11	01'25"564"	13	01'25"564"	01'25"796"
10	Fernandes Jean Marc	F	PVP / DEA	9	01'25"354"	11	01'25"354"	01'25"830"
11	Taloc Mickael	F	PVP / PVP	16	01'27"199"	16	01'27"199"	01'26"898"
12	Joubert Anthony	F	PVP / FPE	18	01'29"296"	18	01'29"047"	01'26"732"
13	Legoubin Arnaud	F	EMA / VM	17	01'27"983"	17	01'27"983"	01'26"481"
14	Vandemeulebroucke Thierry	F	PVP / FPE	12	01'25"923"	14	01'26"642"	01'25"767"
15	Maurin Philippe	F	MSKART / VM	15	01'26"891"	15	01'26"891"	01'25"738"
16	Kinsey Carl	GB	ANDERSON / FPE	7	01'24"571"	8	01'23"706"	01'22"933"
17	Brossard Olivier	F	MSKART / APRILIA	22	01'31"823"	22	01'31"823"	01'28"111"
18	Demuys Xavier	F	MSKART / APRILIA	21	01'31"454"	21	01'31"454"	01'30"419"
19	Lamalle Johan	F	PVP / SGM	8	01'24"656"	9	01'24"656"	01'24"056"
20	Demuys Matthieu	F	MSKART / APRILIA	24		23	01'35"360"	01'33"231"
21	Albin Marc	F	PVP / FPE	13	01'26"309"	10	01'25"144"	01'26"321"
22	Roho Jean Pierre	F	EMA / ROTAX	23		24	01'38"765"	01'33"119"
23	Demuys Ludovic	F	MSKART / APRILIA	19	01'30"492"	20	01'30"492"	01'31"037"
24	Da Cruz Gilles	F	PVP / FPE	20	01'30"577"	19	01'30"261"	01'31"073"

SUPERKART ★ DUNLOP

## NATIONALY

FRANCE	18
SUISSE	2
ROYAUME-UNI	2
ALLEMAGNE	1
PORTUGAL	1

## CHASSIS

PVP	12
MSKART	6
ANDERSON	4
EMA	2

## ENGINES

FPE	11
APRILIA	4
VM	3
PVP	2
DEA	2
SGM	1
ROTAX	1

## TIRES

DUNLOP	24
--------	----



The logo for NS-KARTING.COM consists of the text 'NS-KARTING.COM' in white, uppercase, sans-serif font, centered within a black rectangular background.

By Frédéric Billet / © Photo KSP - Philippe Kalmès

# THE SEASON STARTS AT VARENNES

## KEY POINTS OF THE WEEKEND

Date: 17th and 18th May 2014  
Location: Circuit Jean Brun - Varennes-sur-Allier - 1500 m  
Entry: 203 drivers - 7 categories

→ A beautiful summer weekend on the beautiful Varennes circuit.  
Spectacular racing, including X30 and National races. First competition for  
the FFSA Kart Racing Academy.





# DE RUWE SETS THE BENCHMARK IN DD2

As poleman, heat and prefinal winner and the winner of the final, the Belgian De Ruwe Xen (ART GP) left nothing for his rivals. Renaud Bertin (Formula K) was unable to defend his second place in the final and Romain Mangé (Tony Kart) who took over ahead of Alexis Coursault (Birel), 3rd after a duel with Maxime Gravouille (Sodi).



## SAVARD AT THE FINISH IN DD2 MASTER

Christophe Adams (Kosmic) won the prefinal ahead of Florent Lambert (Tony Kart) and Patrick Giudici (Kosmic), but Yannick Savard (Birel) finally had a clear run in the final, and won ahead of Florent Lambert (Tony Kart) and Morgan Hipp (Tony Kart).

## NATIONALE : ONE SIMMENAUER AGAINST THE OTHER

Jean-Baptiste Simmenauer (Tony Kart / Rotax) won the prefinal, but his elder brother, Louis-Ferdinand (Tony Kart / Rotax) won the final after a fierce race against Anthony Coudert (Kosmic / Rotax) and Nicolas Ville (Tony Kart / Rotax).





# LAMBERT RETURNS RELENTLESSLY IN ROTAX MASTER

Florent Lambert (Tony Kart / Rotax) was a surprise in a beautiful rise of 15 places in the finals which led to the victory podium also rewarding Nicolas Duchateau (Tecno / Rotax) and Christophe Adams (Kosmic / Rotax).



# DOUBLE FOR LOPES IN X30 SENIOR

The battle for victory involved several drivers in X30 Senior, as well as in the prefinal. Jeremy Lopes (Tony Kart / Parilla) however managed to cross the finish line as the winner in both races. Antony Ceribella (Tony Kart / Parilla) took second position after a rise of five places and a good fight against Kevin Breysse (ART GP / Parilla).



# PICOT WINS ROTAX MAX

Despite strong opposition, Nicolas Picot (Sodi / Rotax) carried off the prefinal and final, closely followed by a worthy opponent, Joel Deptuch (FA Kart / Rotax). Pierre-Alexandre Hennequin (Tony Kart / Rotax) was finally able to hold on to 3rd place.



## SUCCESSFUL LAUNCH FOR KART RACING ACADEMY

The karting competition school set up by the FFSA had its first race at the first meeting of the NSK 2014 at Varennes, with ideal weather. 30 apprentice champions competed for the first time on the track, showing both seriousness and great enthusiasm - the public was not bored for a second following the ups and downs of the seven races on the programme.

### A TRUE SCHOOL OF COMPETITION FROM THE FFSA

The Kart Racing Academy facilities looked great in the paddock at Varennes, thanks to a blend of simplicity and efficiency. A great atmosphere, from the young drivers, parents, and the 3mk Event Team organisation, accompanied the sporting success of this first event. Ask Marc Berteaux or Guy Pansart, the "monitors" of the two categories, what they thought and you will get a big happy smile as the first response.

*"We worked hard with our young pupils to make sure that their first competitive event went well," explained the two coaches. "They knew the rules of the event, start procedures and the basics of driving. Dynamism on track resulted in very competitive races. It was great! We will now be able to continue their education in the light of this initial experience."*



## ALEXANDER COLOMÈS AND FAUSTIN MAHÉ DOMINATED THE FIRST COMPETITION FOR THE KART RACING ACADEMY

Two drivers, Alexander Colomès and Faustin Mahé marked the competition by winning every race in their class. In the younger age 7-11 KRA class, driving Sodi / Rotax Minikarts, Guillaume Treillard of Quinumont took pole position after the

two sessions, but Faustin Mahe won three races with great confidence, with Caesar Gazeau twice on the second step of the podium. Victor Bernier finished second in race 2 and third in race 3, while Treillard and Thibault Schencke completed the other podium.

Among 11-15 year olds, on Sodi / Rotax Cadet karts, Alexander Colomès performance commanded respect. Pole man after qualifying, and the winner of four races with the fastest lap each time, Alexander dominated from start to finish thanks to his accurate and consistent lines. The younger brother of

Charles Leclerc, Arthur, showed fighting spirit at all times to take one third and two seconds in the races. Alvis Ang also stood out by getting a 2nd and 3rd place, while Xavier Duvignau, Benjamin Gonzalez and Bastien Flahaut also took podiums.

Sporting equality was ensured with several exchanges of engines between participants, while the stewards rigorously ruled on some race incidents immediately to give the racers good habits.





NSK - VARENNES SUR ALLIER

# LLEDO ALREADY ON THE PACE IN NATIONAL

Tom Lledo competed in his first National NSK event at Varennes, and it was a happy driver who left on Sunday night back to his native south. Tom started in the category this year after an interesting journey from Cadets in 2013. Having made his debut in the main championship for the south, putting together CRK Languedoc-Roussillon and Midi-Pyrénées, he found success in National at the opening round of the NSK driving his Tony Kart, with the support of Suau Racing.

After coming 16th in qualifying out of 57 entries with the third time in his group, Tom gained ground in the heats, despite an incident that was penalised in the last. The tone of the meeting was set: a high level of performance, uncertainties in the battle in the middle of the pack, especially during the starts, and continuous attacks to move up. With 11 places gained in the A-D heat and 12 in the final, Tom never dropped the ball this weekend. His 16th place in the NSK standings means he expects big improvements in the coming events.

*"National is really a nice category," confided the driver on the night of the race. "There's a good level, the battle, and a beautiful track like Varennes, so we celebrated. I wasn't far away from getting into the top 10, which is already a satisfaction for a first national competition as hotly contested as the NSK. I am well aware that there is progress to make, but I have time because I'm not yet 14 years old. In any case, I now appreciate racing in this category."*





By Frédéric Billet / © Photo KSP - Philippe Kalmès

NSK - VARENNES SUR ALLIER

# GOOD OVERALL RESULT FOR THE SIMMENAUIERS AT VARENNES

With international experience, but also due to all the work they have done since the beginning of the season with Jana Racing, Louis-Ferdinand and Jean-Baptiste Simmenauer were successful at the first round of the NSK, organised at Varennes-sur-Allier, in the National category. The younger won the prefinal, while the eldest succeeded in the final.

Although the French national standard is a long way below the European competitions like the Rotax Euro Challenge, the NSK is a good example of successful organisation with intense confrontations throughout the weekend. The National tyres are now

well developed and the technical control is competent and effective, and the meeting looks great. Only the sporting event handling could be improved to preserve a common logic in all European countries and not unnecessarily discourage competitors.

However, the Simmenauer brothers quickly got used to the drafting phenomena and they shared the top rankings in National, along with their teammate Harald Creton. The grip at the track was more important than the team had anticipated and the Tony Kart chassis from Jana Racing did not have a real advantage over the competition. This meant that the merit of the drivers was even greater. During the prefinal, the battle raged

in a tight group of ten contenders where Jean-Baptiste emerged in first position and Louis-Ferdinand in second place in the final laps. A few laps after the start of the final, five drivers were competing for the win. Taking advantage of his experience, Louis-Ferdinand seized the lead and held on until the finish, while Jean-Baptiste fought to the end to finish in fourth position, while setting the second fastest time.

Louis-Ferdinand and Jean-Baptiste were successful, taking a good result that will inflate their ambitions for the next meeting of the Rotax Euro Challenge at Castelletto, although that looks much tougher against the best European specialists.



# SIMMENAUIERS



## TEAM KPR

By Frédéric Billet / © Photo KSP - Philippe Kalmès

NSK - VARENNES SUR ALLIER

BIG WIN FOR  
NICOLAS PICOT AT  
NSK VARENNES

**K**art Pro Racing found it hard to hide their satisfaction after the victory for Nicolas Picot in Rotax Max at the first round of the 2014 NSK. "On a circuit like Varennes it's a great reward for a driver," says Dominique Check. "The long development work on the dyno for Rotax in 2014 has paid off! Nicolas' engine is proven, he was untouchable at both at high and low speeds."

Nicolas Picot has indeed had a big effect on the category. Blocked on his fastest lap in qualifying, he set the sixth time, but came back to the lead in the heats, apart from a clash in the last heat. 2nd in the intermediate classification, he was on the attack in the prefinal for pole position on the starting grid for the final. *"I didn't think he'd be able to stay in front throughout the race. At Varennes, this is very rare,"* explained Dominique. *"But adjusting the carburettor after the prefinal proved decisive. Nicolas was able to handle the pressure of Joel Deptuch behind him, a driver with exemplary behaviour elsewhere. Nicolas had enough power to avoid being passed from the tow, and he was even able to increase the pace at the end."*

Picot set the fastest time on the last of the 20 laps of the race. In addition to the driver and the engine, the performance is a credit to the chassis, the strictly standard Sodi Sigma S3, which was

effective throughout in the heat and the grip at Varennes. Now more stable as a full time mechanic at Kart Pro Racing, Nicolas Picot has shown great maturity and has given excellent results in testing to effectively add to the hours spent on the engine bench to improve the machinery faster.

Of the other drivers at the KPR team at Varennes, in Rotax Max Mathias Vaison finished 7th in the prefinal, and Kevin Petit rebounded with a 14th in the final with a hastily straightened frame. There was good progress for Marc Cammarata, 11th in National, ahead of Adrien Renaudin, slowed somewhat by what turned out to be a lack of grip. For his first race in DD2, Alexandre Anstett, in 5th, competed with the experienced Maxime Gravouille in 4th. Bruno Dos Santos and Mathieu Camus moved up to the top 10 in Rotax Master after mixed fortunes in the heats.

*"The NSK showed that we have very good potential this season,"* Dominique Check concluded. *"I think Nicolas has a good card to play in the Euro Challenge. Whether the NSK or the French Championship, we can still support other drivers to the top."*



P.	Pilote	Nat.	Chr 1	Temps Chr 1	Course 1	Temps C. 1	Chr 2	Temps Chr 2	Course 2	Temps C. 2	Course 3	Temps C. 3
1	Mahe Faustin	F	3	01'10"366"	1	01'10"531"	2	01'11"008"	1	01'10"583"	1	01'10"414"
2	Gazeau Cesar	F	2	01'10"309"	2	01'10"167"	4	01'11"221"	7	01'10"897"	2	01'10"204"
3	Bernier Victor	F	4	01'10"942"	7	01'10"590"	7	01'11"734"	2	01'10"562"	3	01'10"169"
4	Treillard De Quinmont Guillaume	F	1	01'10"164"	5	01'10"405"	1	01'10"766"	3	01'10"415"	4	01'10"328"
5	Schencke Thibault	F	7	01'11"248"	3	01'10"294"	6	01'11"691"	12	01'11"485"	5	01'10"540"
6	Jouniaux Simon	F	6	01'11"233"	4	01'10"492"	3	01'11"219"	8	01'11"217"	6	01'10"634"
7	Jeanjean Nicolas	F	9	01'11"747"	15		11	01'12"696"	4	01'11"169"	8	01'11"078"
8	Merieux Tim	F	8	01'11"358"	6	01'11"626"	9	01'12"020"	5	01'11"336"	15	01'12"215"
9	Monier Paul	F	10	01'12"252"	8	01'12"156"	13	01'13"251"	9	01'12"974"	11	01'11"975"
10	Vayron Eliot	F	12	01'12"483"	14	01'11"850"	8	01'11"856"	6	01'11"262"	9	01'12"277"
11	Schin Oua Siron Greg	F	5	01'11"186"	P 9	01'10"655"	5	01'11"683"	13	01'11"904"	7	01'10"888"
12	Saintpaul Elio	F	11	01'12"380"	12	01'11"854"	10	01'12"677"	10	01'12"357"	10	01'11"901"
13	Roussel Jules	F	13	01'14"045"	10	01'12"927"	12	01'12"981"	11	01'12"990"	12	01'13"473"
14	Charraud Cleophee	F	14	01'15"563"	11	01'14"915"	14	01'15"963"	14	01'14"985"	13	01'15"350"
15	Richer Enzo	F	15	01'15"773"	13	01'17"998"	15	01'18"996"	15	01'15"460"	14	01'16"300"

KRA 7 -11 ★ SODI ★ VEGA

P.	Pilote	Nat.	Chr 1	Temps Chr 1	Course 1	Temps C. 1	Chr 2	Temps Chr 2	Course 2	Temps C. 2	Course 3	Temps C. 3	Course 4	Temps C. 4
1	Colomes Alexandre	F	1	01'03"802"	1	01'03"849"	1	01'03"724"	3	01'04"744"	1	01'04"187"	1	01'03"661"
2	Leclerc Arthur	F	2	01'03"973"	3	01'04"229"	2	01'04"010"	5	01'05"113"	2	01'04"508"	P 8	01'04"719"
3	Gonzalez Benjamin	F	7	01'04"306"	4	01'04"316"	5	01'03"943"	10	01'05"351"	5	01'04"647"	2	01'04"002"
4	Flahaut Bastien	F	10	01'04"649"	10	01'04"683"	4	01'03"864"	7	01'05"189"	8	01'04"409"	3	01'04"279"
5	Ang Alvis	F	6	01'04"250"	2	01'03"949"	DC		1	01'04"695"	3	01'04"486"	11	01'04"476"
6	Duignau Xavier	F	5	01'04"228"	11	01'04"583"	3	01'03"985"	9	01'05"302"	7	01'04"951"	14	01'05"450"
7	Permal Guillaume Emmanuel	F	3	01'04"105"	6	01'04"318"	14	01'04"446"	2	01'04"712"	4	01'04"609"	10	01'04"759"
8	Hebrard Sacha	F	14	01'05"208"	7	01'05"226"	8	01'04"525"	8	01'05"197"	10	01'04"851"	5	01'04"287"
9	Faridoni Antoine	F	9	01'04"640"	12	01'04"923"	10	01'04"303"	6	01'05"174"	15	01'04"211"	4	01'04"392"
10	Bourgin Pierrick	F	8	01'04"573"	14	01'04"906"	7	01'04"509"	12	01'05"748"	11	01'04"876"	6	01'04"282"
11	Lambert Neo	F	4	01'04"165"	5	01'04"408"	11	01'04"351"	4	01'04"833"	6	01'04"716"	DC	
12	Lachieze Antoine	F	12	01'04"960"	9	01'05"246"	9	01'04"755"	11	01'05"359"	13	01'05"594"	9	01'05"036"
13	Aimable Gavin	F	13	01'05"112"	8	01'04"923"	6	01'04"792"	13	01'06"288"	14	01'04"974"	13	01'06"213"
14	Puel Louis	F	11	01'04"774"	13	01'05"393"	13	01'05"036"	14	01'06"427"	9	01'04"608"	7	01'04"535"
15	Kuwabara Wagg Julian	F	15	01'06"048"	15	01'06"255"	12	01'05"848"	15	01'06"500"	12	01'05"509"	12	01'04"170"

KRA 11 -15 ★ SODI ★ BRIDGESTONE

P.	Pilote	Nat.	Mat.	Chr.	Tps.	Inter.	Pre-Fin.	Tps	Fin.	Tps
1	De Ruwe Xen	B	ART GP	1	54"676"	1	1	55"077"	1	54"965"
2	Mange Romain	F	TONY KART	2	55"004"	10	6	55"121"	2	55"010"
3	Coursault Alexis	F	BIREL	4	55"100"	3	4	55"346"	3	54"987"
4	Gravouille Maxime	F	SODI	5	55"160"	4	3	55"186"	4	55"056"
5	Anstett Alexandre	F	SODI	7	55"355"	5	5	55"363"	5	55"166"
6	Bertin Renaud	F	FORMULA K	3	55"057"	2	2	55"331"	6	55"023"
7	Joly Lucas	F	TONY KART		DC	7	7	55"419"	7	55"399"
8	Renaudin Julien	F	SODI	8	55"556"	6	8	55"469"	8	55"491"
9	Billings Jamie	F	TONY KART	9	55"588"	8	9	55"923"	9	55"643"
10	Miel Sebastien	F	CRG	10	56"067"	9	10	56"237"	10	55"832"
11	Coneys Ulysse	F	TONY KART	6	55"354"	11	11		11	

DD2 ★ MOJO

P.	Pilote	Nat.	Mat.	Chr.	Tps.	Inter.	Pre-Fin.	Tps	Fin.	Tps
1	Savard Yannick	F	BIREL	3	55"622"	4	6	55"734"	1	55"322"
2	Lambert Florent	GB	TONY KART	1	55"461"	5	3	55"557"	2	55"483"
3	Hipp Morgan	F	SODI	11	01'05"819"	8	7	55"893"	3	55"633"
4	Bourdon Florian	F	KOSMIC	7	56"248"	6	4	55"708"	4	55"498"
5	Adams Christophe	F	KOSMIC	2	55"524"	1	2	55"668"	5	55"522"
6	Rouxel Franck	F	SODI	5	55"846"	2	1	55"792"	6	55"611"
7	Giudici Patrick	F	KOSMIC	4	55"790"	3	5	55"726"	7	55"614"
8	Prouteau Franck	F	BIREL	10	58"298"	10	9	58"537"	8	57"630"
9	Carbonnel Lionel	F	BIREL	9	57"689"	11	11	59"810"	9	58"188"
10	Billings Ronald	F	TONY KART	6	56"004"	7	8	55"981"	10	56"403"
11	Cornee Thomas	F	CRG	8	56"725"	9	10	56"888"	11	

DD2 MASTER ★ MOJO



P.	Pilote	Nat.	Mat.	Chr.	Tps.	Inter.	Pre-Fin.	Tps	Fin.	Tps
1	Lopes Jeremy	F	TONY KART	24	57"353"	11	1	56"772"	1	56"870"
2	Ceribella Anthony	F	TONY KART	8	56"894"	2	7	56"803"	2	56"704"
3	Barbe John	F	TONY KART	2	56"488"	1	3	56"802"	3	56"765"
4	Barbarin Guillaume	F	TONY KART	12	57"014"	6	4	56"763"	4	56"525"
5	Ricci Thomas	F	TONY KART	5	56"668"	3	5	56"823"	P 5	56"702"
6	Cout Anthony	F	ALPHA	3	56"607"	5	8	56"902"	6	56"927"
7	Breyse Kevin	F	ART GP	1	56"330"	8	6	56"967"	7	56"850"
8	Midali Luca	F	SODI	10	56"927"	16	9	56"869"	8	56"927"
9	Bouzana Flavien	F	FA KART	35	57"826"	32	15	56"960"	9	56"854"
10	Potain Mickael	F	KOSMIC	27	57"443"	15	13	56"966"	10	56"951"
11	Felicioni Enzo	F	TONY KART	29	57"481"	17	23	57"123"	11	57"147"
12	Garcia Sylver	F	OK1	11	56"933"	12	2	56"639"	12	57"194"
13	Dapigny Quentin	F	KOSMIC	19	57"262"	27	21	57"116"	13	57"192"
14	Jolinet Gregory	F	TONY KART	32	57"675"	25	25	57"222"	14	57"193"
15	Legarda Alexandre	F	KOSMIC	9	56"913"	7	34	01'09"107"	15	57"093"
16	Bourassin Johan	F	TONY KART	15	57"074"	9	10	56"788"	16	57"175"
17	Borges Martins Matthias	F	FORMULA K	28	57"446"	19	31	57"384"	17	57"280"
18	Mazgarean Yoann	CH	SODI	25	57"367"	26	19	57"188"	18	57"592"
19	Monier Matthieu	F	ENERGY	34	57"739"	30	28	57"790"	19	57"564"
20	Billet Pierre	F	TONY KART	37	58"014"	35	26	57"301"	20	57"694"
21	Vinel Arnaud	F	TONY KART	36	57"950"	36	32	59"027"	21	57"712"
22	Coulange Rudy	F	TONY KART	30	57"482"	31	27	57"251"	22	57"564"
23	Romulus Lucas	F	ENERGY	22	57"348"	22	20	57"084"	23	57"599"
24	Rouchy Jeffrey	F	CRG	20	57"275"	29	16	56"921"	24	56"852"
25	Quezada Romain	F	ENERGY	17	57"185"	24		DC	25	57"601"
26	Lesca Steven	F	SODI	14	57"061"	21	17	57"083"	26	57"287"
27	Rongier Quentin	F	KOSMIC	7	56"796"	4	11	57"172"	27	57"216"
28	Napolitano Giacomo	F	TONY KART	4	56"664"	14	22	56"845"	28	57"243"
29	Meunier Evan	F	TECNO	16	57"169"	28	14	56"899"	29	57"046"
30	Chillet Clement	F	PCR	33	57"687"	23	18	57"146"	30	57"446"
31	Godefroid William	B	KOSMIC	13	57"036"	10	33	59"176"	31	57"396"
32	Castellon Alexis	F	TECNO	26	57"422"	13	12	57"098"	32	57"911"
33	Andriamiharisoa Thomas	F	TONY KART	23	57"348"	20	29	58"304"	33	58"344"
34	Pernet Cedric	F	TONY KART	31	57"520"	33	24	57"059"	34	
35	Rinaudo Thibault	F	CRG	21	57"319"	34	30	57"721"	35	
36	Heron Bastien	F	KOSMIC	6	56"738"	18	35			
37	De La Brosse Baptiste	F	ALPHA	18	57"222"	37	36			

X30 SENIOR ★ PARILLA ★ COMET

P.	Pilote	Nat.	Matériel	Chr.	Tps	Inter.	Pre-Fin.	Tps	consolante	Tps	Fin.	Tps
1	Simmenauer Louis Ferdinand	F	TONY KART	5	58"381"	2	2	58"744"			1	
2	Coudert Anthony	F	KOSMIC	9	58"518"	4	4	58"575"			2	
3	Ville Nicolas	F	TONY KART	2	58"269"	8	9	58"622"			3	
4	Simmenauer Jean Baptiste	F	TONY KART	15	58"619"	3	1	58"684"			4	
5	Creton Harald	F	TONY KART	8	58"438"	1	3	58"812"			5	
6	Carde Emilien	F	KOSMIC	3	58"351"	21	27	59"394"			6	
7	Gelormini Luca	F	FORMULA K	1	58"253"	16	15	58"664"			7	
8	Drouet Thomas	F	FA KART	27	58"878"	37	14	59"002"			8	
9	Carton Romain	F	TONY KART	33	58"985"	24	20	58"988"			9	
10	Leuillet Tom	F	BIREL	10	58"519"	5	5	58"741"			P 10	
11	Cammarata Marc	F	SODI	42	59"122"	29	22	59"138"			11	
12	Renaudin Adrien	F	SODI	29	58"938"	7	25	58"937"			12	
13	Perceval Antoine	F	TONY KART	6	58"383"	9	12	58"829"			13	
14	Leuillet Gabin	F	BIREL	38	59"073"	28	29	59"609"			14	
15	Chassagneux Antoine	F	TONY KART	4	58"372"	11	28	59"479"			15	
16	Gilloz Valentin	F	TONY KART	20	58"656"	17	11	58"697"			16	
17	Baudot Geoffrey	F	FORMULA K	21	58"766"	33	17	59"430"			17	
18	Lledo Tom	F	TONY KART	16	58"619"	13	16	59"185"			18	
19	Mary Bastien	F	TONY KART	26	58"848"	26	26	59"362"			19	
20	Lemee Thomas	F	KOSMIC	19	58"655"	18	18	58"846"			20	
21	Cappello Christopher	F	OK1	31	58"957"	30	24	59"207"			21	
22	Vromant Alexandre	F	ZANARDI	12	58"537"	10		DC			22	
23	Hericher Bertrand	F	KOSMIC	24	58"827"	32	34	01'02"892"			23	
24	Usanna Anthony	F	TONY KART	43	59"167"	40	P 32	58"996"			24	
25	Breuil Marina	F	PCR	17	58"633"	19	10	58"682"			25	
26	Servier Emma	F	BIREL	50	59"556"	34	30	59"276"			26	
27	Gomes Maximilien	F	TONY KART	52	59"682"	25	33	59"842"			27	
28	Baverel Paul	F	TONY KART	23	58"818"	12	P 21	58"955"			28	
29	Mela Jean Baptiste	F	BIREL	34	59"006"	27	19	58"916"			29	
30	Hedouin Nathan	F	SODI	11	58"533"	6	6	58"792"			30	
31	Fontaine Paul	F	FA KART	36	59"024"	20	23	59"339"			31	
32	Herblot Vincent	F	TONY KART	7	58"396"	14	13	58"824"			32	
33	Andlauer Julien	F	OK1	18	58"640"	22	7	58"809"			33	
34	Ferrer Camille	F	TONY KART	13	58"541"	15		DC			34	
35	Marion Aurelien	F	TONY KART	25	58"837"	23	8	58"642"			35	
36	Bonnaire Alexandre	F	BIREL	37	59"033"	47	31	59"536"			36	
37	Fenestraz Sacha	F	TONY KART	41	59"113"	39			1	58"823"		
38	Beumann David	F	KOSMIC	45	59"271"	31			2	59"281"		
39	Potain Jeremy	F	KOSMIC	30	58"940"	35			3	59"074"		
40	Dabert Pauline	F	SODI	39	59"086"	41			4	59"470"		
41	Bacconnet Kilian	F	OK1	40	59"095"	42			5	59"410"		
42	Ancher Brian	F	KOSMIC	54	59"835"	53			6	59"624"		
43	Augier Manon	F	FORMULA K	51	59"603"	52			7	59"696"		
44	Marie Francois	F	OK1	47	59"325"	51			8	59"928"		
45	Teneketian William	F	KOSMIC	46	59"279"	48			9	01'00"024"		
46	Bihel Natan	F	TONY KART	35	59"016"	50			10	01'00"052"		
47	Gardet Alexi	F	OK1	55	59"866"	45			11	01'00"167"		
48	Bouley Manon	F	SODI	57	01'00"473"	55			12	01'00"134"		
49	Claude Emile	F	BIREL	44	59"172"	44			13	01'00"102"		
50	Barrere Axel	F	TONY KART	56	59"882"	56			14	59"506"		
51	Pierrat Clement	F	TONY KART	53	59"784"	54			15	59"582"		
52	Ibanez Francois	F	FA KART	48	59"337"	38			16	59"722"		
53	Durand Louis	F	KOSMIC	28	58"900"	46			17	59"982"		
54	Hucher Nathan	F	ENERGY	49	59"444"	36			18			
55	Tramontin Antonin	F	KOSMIC	14	58"580"	43				DC		
56	Charpentier Tristan	F	FA KART	32	58"957"	49						
57	Devanlay Julien	F	TONY KART	22	58"796"							

NATIONALE ★ ROTAX ★ MOJO



RESULTS

P.	Pilote	Nat.	Mat.	Chr.	Tps.	Inter.	Pre-Fin.	Tps	Fin.	Tps
1	Lambert Florent	GB	TONY KART	6	58"270"	5	16	58"758"	1	58"328"
2	Duchateau Nicolas	F	TECNO	8	58"467"	4	6	58"161"	2	58"110"
3	Adams Christophe	F	KOSMIC	4	58"236"	3	5	58"148"	3	58"352"
4	Charon Jeremie	F	TONY KART	1	57"777"	2	2	57"844"	4	58"192"
5	Hipp Charly	F	TONY KART	3	58"087"	1	1	58"497"	5	58"333"
6	El Khechen Rami	F	OK1	15	58"978"	8	10	58"436"	6	58"633"
7	Dos Santos Bruno	F	SODI	9	58"623"	13	8	58"410"	7	58"630"
8	Camus Mathieu	F	SODI	13	58"868"	15	18	58"809"	8	58"734"
9	Bourdais Christian	F	EXCEED	2	57"933"	6	7	58"081"	9	58"533"
10	Rimmaudo Gilles	F	TONY KART	11	58"744"	16	14	59"218"	10	58"955"
11	De Vito Rodolphe	F	TONY KART	14	58"932"	11	11	58"755"	11	58"993"
12	Bouteiller Yan	F	KOSMIC		DC	20	13	59"040"	12	59"041"
13	Paris Olivier	F	SODI	5	58"252"	9	3	58"260"	13	58"460"
14	Delavier Eric	F	TONY KART	12	58"850"	10	12	58"975"	14	59"498"
15	Lecroq Fabrice	F	SODI	19	01"00"025"	18	17	59"929"	15	59"532"
16	Renault Lionel	F	TONY KART	18	59"650"	17	15	59"624"	16	59"953"
17	Giudici Patrick	F	KOSMIC	7	58"290"	7	4	58"402"	17	58"551"
18	Grabia Gaby	F	TONY KART	16	59"300"	19		DC	18	59"703"
19	Raccamier Thierry	F	KOSMIC	10	58"689"	12	9	58"498"	19	58"974"
20	Barth Didier	F	KOSMIC	17	59"435"	14	19		20	01"09"146"
21	Leguillon Franck	F	TONY KART	20						

ROTAX MASTER

P.	Pilote	Nat.	Mat.	Chr.	Tps.	Inter.	Pre-Fin.	Tps	Fin.	Tps
1	Picot Nicolas	F	SODI	6	57"137"	2	1	57"306"	1	58"328"
2	Deptuch Joel	F	FA KART	5	57"101"	12	2	57"000"	2	58"110"
3	Pennequin Pierre-alexandre	F	TONY KART	8	57"370"	4	3	57"246"	3	58"352"
4	Falchero Julien	F	KOSMIC	16	57"533"	6	4	57"265"	4	58"192"
5	Pozzoli Xavier	F	KOSMIC	19	57"601"	14	11	57"013"	5	58"333"
6	Cool Michael	B	TONY KART	3	57"069"	9	9	57"302"	6	58"633"
7	Petit Hubert	F	TONY KART	7	57"336"	3	12	57"411"	7	58"630"
8	Benes Eva	F	KOSMIC	1	56"922"	5	14	57"035"	8	58"734"
9	Cousin Jules	F	FA KART	2	57"064"	1	8	57"405"	9	58"533"
10	Evrard Paul	F	KOSMIC	9	57"386"	7	10	57"362"	10	58"955"
11	Revirault Emmanuel	F	CRG	4	57"078"	16	29	57"171"	11	58"993"
12	Vaison Mathias	F	SODI	14	57"484"	10	7	57"311"	12	59"041"
13	Pennequin Jean-baptiste	F	TONY KART	13	57"465"	11	5	57"277"	13	58"460"
14	Petit Kevin	F	SODI	11	57"407"	18	P 20	57"235"	14	59"498"
15	Deheegher Remi	F	KOSMIC	27	57"843"	27	16	57"107"	15	59"532"
16	Becq Gautier	F	SODI	28	57"861"	15	13	57"443"	16	59"953"
17	Fotia Anthony	F	SODI	15	57"497"	8	18	57"686"	17	58"551"
18	Rambaud Sebastien	F	TONY KART	18	57"580"	13	25	57"683"	18	59"703"
19	Agoulon Quentin	F	SODI	25	57"800"	22	17	57"595"	19	58"974"
20	Jeanvoine Vincent	F	TONY KART	31	58"097"	24	24	57"812"	20	01"09"146"
21	Martini Cecile	F	SODI	33	58"310"	28	30	58"500"	21	
22	Aguillon Valentin	F	KOSMIC	23	57"756"	23	27	58"320"	22	
23	Hodier Thomas	F	TONY KART	32	58"213"	25	33	58"356"	23	
24	Antier Antoine	F	KOSMIC	22	57"693"	33	26	58"004"	24	
25	Gimbert Maxime	F	KOSMIC	34	58"486"	29	P 32	58"654"	25	
26	Valentin Brice	F	TONY KART	29	57"873"	31	28	58"091"	26	
27	Mially Thomas	F	OK1	30	58"016"	26	31	57"814"	27	
28	Miquel Antoine	F	SODI	21	57"628"	20	21	57"649"	28	
29	Spirli Julien	F	TONY KART	12	57"442"	30	22	57"406"	29	
30	Melet Matthieu	F	TONY KART	10	57"387"	17	6	57"147"	30	
31	Bonnan Arnaud	F	KOSMIC	26	57"841"	34	23	57"553"	31	
32	Landais Thomas	F	TONY KART	24	57"761"	21	19	57"364"	32	
33	Fraisse Vincent	F	SODI	20	57"626"	19	15	57"277"	33	
34	Williamson Andrew	F	SODI	36		32		DC	34	
35	Trouttet Victor	F	SODI	35	58"869"	35	34			
36	Leguay Bastien	F	TONY KART	17	57"569"	36				

ROTAX MAX



## NATIONALITY

FRANCE	197	<div style="width: 100%;"></div>
BELGIQUE	3	<div style="width: 1%;"></div>
ROYAUME-UNI	2	<div style="width: 1%;"></div>
SUISSE	1	<div style="width: 1%;"></div>

## CHASSIS

TONY KART	62	<div style="width: 100%;"></div>
SODI	58	<div style="width: 93%;"></div>
KOSMIC	33	<div style="width: 53%;"></div>
BIREL	10	<div style="width: 16%;"></div>
OKI	8	<div style="width: 13%;"></div>
FA KART	7	<div style="width: 11%;"></div>
CRG	5	<div style="width: 8%;"></div>
FORMULA K	5	<div style="width: 8%;"></div>
ENERGY	4	<div style="width: 6%;"></div>
TECNO	3	<div style="width: 5%;"></div>
PCR	2	<div style="width: 3%;"></div>
ART GP	2	<div style="width: 3%;"></div>
ALPHA	2	<div style="width: 3%;"></div>
ZANARDI	1	<div style="width: 2%;"></div>
EXCEED	1	<div style="width: 2%;"></div>

## ENGINES

ROTAX	166	<div style="width: 100%;"></div>
PARILLA	37	<div style="width: 22%;"></div>

## TIRES

MOJO	136	<div style="width: 100%;"></div>
KOMET	37	<div style="width: 27%;"></div>
BRIDGESTONE	15	<div style="width: 11%;"></div>
VEGA	15	<div style="width: 11%;"></div>



WELCOME TO THE MOST POPULAR  
**KART LEISURE RANKING OF THE WORLD**

SWS is more than : 20 000 Drivers - 1 300 Races/year - 130 Tracks on 5 Continents

**Become a SWS driver and race the world !**

**Free registration** on [www.sodiwseries.com](http://www.sodiwseries.com)



# FRENCH CHAMPIONSHIP OSTRICOURT

By Frédéric Billet © Photo KSP - Jean-Claude Constans

**FFSA**  
KARTING

## TWO CHAMPIONS AT OSTRICOURT

### KEY POINTS OF THE WEEKEND

Date: May 31st and June 1st, 2014  
Location: Circuit de la Métropole • Ostricourt • 1500 m  
Entry: 129 drivers • 4 categories

- French Championship for Rotax Max and Rotax Master
- 1st of 3 rounds of the French Championship for Minime / Cadet
- 129 drivers from 9 years old to over 32 years
- Guaranteed show at Ostricourt due to careful organisation and a beautiful circuit.



# HUBERT PETIT, FRENCH ROTAX MAX CHAMPION



An eclectic driver whose path has come through KF3, KF2, then X30 and Rotax, both in national and international races, Hubert Petit (Tony Kart / Rotax) has won his first French Championship at 18 on home turf at Ostricourt. The polesitter Jules Cousin (FA Kart / Rotax) was his most challenging rival, dominating the heats. But Petit's motivation allowed him to win the prefinal and final. The revelation of the day was Louis Scherpereel (Tony Kart / Rotax), among the few to keep up the frenzied pace of the two leaders. He was on the 3rd step of the podium.

## CHARLY HIPPI, EXPERT IN ROTAX MASTER

Coming from a family of passionate racers, Charly Hipp (Tony Kart / Rotax) was clearly delighted with his national crown in the evening at Ostricourt. After racing in 125cc gearbox, he seriously launched his campaign, alternating Rotax Max and DD2, in 2012, and this year he has won his first French Championship. Charly dominated the whole competition and behind him the finest battles raged between Matthew Bourdon (Tony Kart) the Vice-Champion, Jacques Gautier (Sodi / Rotax) 3rd and Cyrille Bracquart (Birel / Rotax) who had to give way in the final against Bruno Dos Santos (Sodi / Rotax).





# MINIME : SOPHIE AHEAD OF THE BOYS!

Sophie Perrin (Zanardi / Parilla) was able to make the difference against her male opponents since qualifying, with three heat wins and the prefinal and final. Milane Petelet (Alpha / Parilla) and Gillian Henrion (OTK / Parilla) didn't make it easy, but Sophie always managed to pass them. Second in the prefinal, Henrion gave the second step of the podium away to Petelet in the final while Enzo Leveque (Zanardi / Parilla) won his battle with Alexander Picque (Zanardi / Parilla) to take 4th place.



# CADET : POURCHAIRE OPENS BUT SABIN CONCLUDES

The leader after qualifying, Theo Pourchaire (CRG / Rotax) could not complete his victorious battle in the final due to several scuffles. Already second in the prefinal, Maxime Sabin (OTK / Rotax) kept going through adversity and emerged in the lead before pulling away to win the race ahead of Timothy Peisselon (CRG / Rotax) and Hugo Szymanski (CRG / Rotax) who outstripped Enzo Valente (Sodi / Rotax) at the end.





New Kinetic 2013

# ENERGY POWER

## PALMARES 2013

WSK Euro Series KF  
WSK Master Series KF  
CIK-FIA International  
KZ2 Super Cup

**KZ2**  
Dorian Boccolacci

**ENERGY CORSE S.R.L.**

via Nazionale, 93  
24068 Seriate BG Italia  
info@energycorse.com  
www.energycorse.com



WEB

## ALPHA KARTING

### EVS R4 NECK JUNIOR

EVS R4 Junior Collar  
Lightweight and  
comfortable

A model with an adjustable quick release system. Protecting the neck and reducing the risk of compression.

Rubberised edges for maximum comfort.



119€  
INC VAT



WEB

## ACTION KARTING

### SPARCO METROPOLIS TRAVEL BAG WITH WHEELS

Equipped with wheels and a sliding handle, the large capacity bag (H.40 x L.91 x P.37) is very tough thanks to its polyester composition. Composed of three main compartments on the top and plenty of pockets, the Metropolis bag includes a multitude of places for all your equipment.

The "plus" of the Metropolis bag is a large lower compartment, accessible after opening the closure and rotating the top. You can then store your race suit flat, without crumpling. This is definitely the perfect bag that will allow you to take care of your equipment and with an aesthetic that will only attract attention!

158€  
INC VAT



WEB

## ITAKA

### HELMET DRYING RACK

**Practical:** tidy on the wall  
**Economical:** low power consumption.  
**Environmentally friendly:** 100% recyclable material.  
**Patriotic:** product made in France.

This helmet holder and drying rack helps the helmet to dry and deodorize the while protecting against falls.

Its innovative design using injected polycarbonate gives it a fresh, modern look.

#### ADVANTAGES:

**Innovative:** a dry helmet (choice of drying time > 45 min for fast drying or 90 min), deodorized and scented (with a long interchangeable cartridge).

#### KIT CONTENTS:

Door helmet dryer +  
Transformer 12V output  
+ Wall Mount + Scented  
Cartridge



125€  
INC VAT







CIRCUIT

# CIRCUIT GENK

 BELGIQUE

GPS  
0°59'13" N / 5°34'00" E  
Google Map  
Length : 1 360 m  
Width : 8-13 m

CAMPING  
Camping Soete dal, Zutendaal

[WWW.SOETEDAL.BE](http://WWW.SOETEDAL.BE)

ASN : RACB SPORT  
rue d'Arlon 53 - 1040 Bruxelles - Belgium  
Tél.: +32 2 287 09 60  
Fax: +32 2 675 61 19  
E-mail : [ww.sport@racb.com](mailto:ww.sport@racb.com)

[WWW.RACB.COM](http://WWW.RACB.COM)

- HOTELS
- ↪ Arte Hotel, Genk (3km)  
Tél : +32 89 35 20 06  
Fax: +32 89 36 10 36
  - ↪ Ecu Genk (3km)  
Tél : +32 89 36 42 44  
Fax : +32 89 36 42 50
  - ↪ Hotel Atlantis, Genk (3km)  
Tél : +32 89 35 65 51  
Fax : +32 89 35 35 29
  - ↪ Golfhotel Stiemerheide, Genk (3km)  
Tél : +32 89 35 58 28  
Web : [www.stiemerheide.be](http://www.stiemerheide.be)
  - ↪ Mardaga Hotel, Genk (4km)  
Tél : +32 89 65 62 65  
Fax : +32 89 65 62 66
  - ↪ Carbon Hotel, Genk (5km)  
Tél : +32 89 32 29 20  
E-mail : [info@carbonhotel.be](mailto:info@carbonhotel.be)
  - ↪ M Hotel, Genk (5km)  
Tél : +32 89 36 41 50  
Fax : +32 89 36 41 51
  - ↪ Monika, Zutendaal (9km)  
Tél : +32 89 61 20 33  
Fax : +32 89 61 19 52

CIRCUIT  
Circuit Horensbergdam - Damstraat 1 -  
3600 Genk - Belgium  
Tél. : +32 89 65 81 82  
Fax : +32 89 65 85 32  
E-mail : [info@kartinggenk.be](mailto:info@kartinggenk.be)

[WWW.KARTINGGENK.BE](http://WWW.KARTINGGENK.BE)

AIRPORT  
Maastricht/NL (25km)  
Brussels-Zaventem (90km)  
Charleroi (130KM)

TRAIN  
Genk (4 km)

TOURIST OFFICE  
V.V.V. Genk - Dielplan 2  
3600 Genk - Belgium  
Tél. : +32 89 30 95 62  
E-mail : [toerisme@genk.be](mailto:toerisme@genk.be)

[WWW.GENK.BE](http://WWW.GENK.BE)



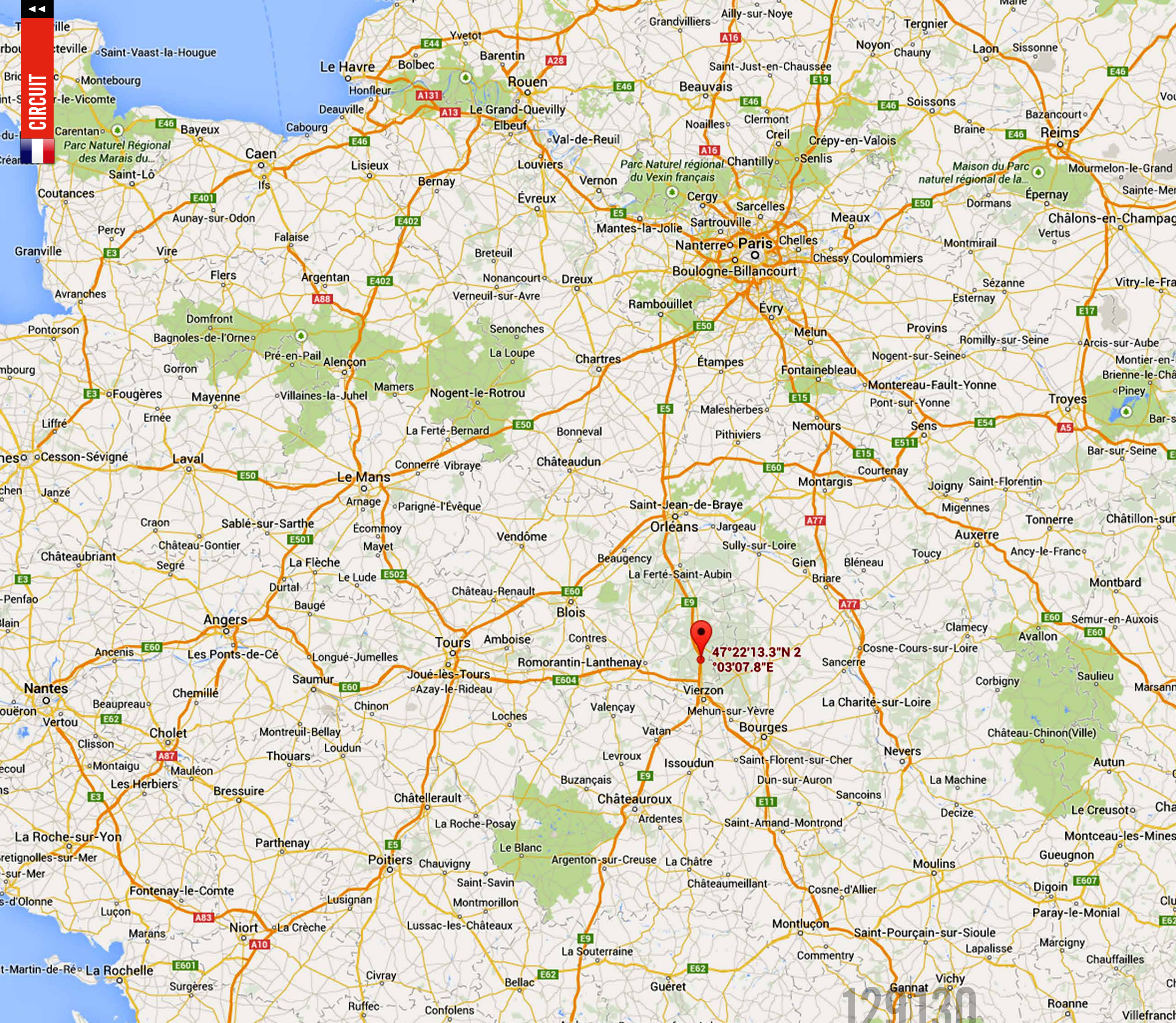

# CIRCUIT SALBRIS FRANCE

## GPS

47°45'00" N - 2°03'04" E

Google Map

Longueur : 1 500 m

Largeur : 8 m

## ASN : FFSA

32 Avenue de New York

75781 Paris Cedex 16 - France

Tél. : +33 1 44 30 24 00

Fax : +33 1 42 24 17 35

E-mail : jgoisque@ffsa.org

[WWW.FFSA.ORG](http://WWW.FFSA.ORG)

## CIRCUIT

Sologne Karting - RN 20

41300 Salbris - France

Tél. : +33 254 972 840

Fax : +33 254 971 564

E-mail : info@sologne-karting.com

[SOLOGNE-KARTING.COM](http://SOLOGNE-KARTING.COM)

## AIRPORT

Orly (186 km)

## TRAIN

Vierzon (22 km)

## TOURIST OFFICE

Sologne des Rivières - 27 boulevard de la

République - 41300 Salbris - France

Tél. : +33 2 54 97 22 27

Fax : +33 2 54 97 22 27

E-mail : contact@tourisme-

solognedesrivers.fr

[TOURISME-SOLOGNESRIVIERES.FR](http://TOURISME-SOLOGNESRIVIERES.FR)

## CAMPING

Camping du circuit



CIRCUIT



# CIRCUIT LE MANS FRANCE

GPS  
47°56'33" N 0°12'50" E  
Google Map  
Longueur : 1 368 m  
Largeur : 8 m

ASN : FFSA  
32 Avenue de New York  
75781 Paris Cedex 16 - France  
Tél. : +33 1 44 30 24 00  
Fax : +33 1 42 24 17 35  
E-mail : jgoisque@ffsa.org

[WWW.FFSA.ORG](http://WWW.FFSA.ORG)

CIRCUIT  
Circuit International Le Mans Karting  
Route du chemin aux boeufs  
72100 Le Mans – France  
Tél. : +33 2 43 40 21 47  
Fax : +33 2 43 40 21 49  
E-mail : ask.aco@lemans.org

[LEMANSDRIVER.FR](http://LEMANSDRIVER.FR)

AIRPORT  
Orly ( 203 km )

TRAIN  
Le Mans

TOURIST OFFICE  
16 rue de L'Étoile  
72 000 Le Mans - France  
Tél. : +33 2 43 28 17 22  
Fax : +33 2 43 28 12 14

[LEMANS-TOURISME.COM](http://LEMANS-TOURISME.COM)

CAMPING  
Camping du circuit  
[www.lemansdriver.fr](http://www.lemansdriver.fr)





**AUTO SPORT  
ACADEMY**  
BY **FFSAI**

AUTO SPORT ACADEMY

Info AUTO SPORT ACADEMY / © Photo KSP - Guillaume Veuve

AUTO SPORT ACADEMY

# F4 : BOCCOLACCI IN CONTROL AT PAU

The young French driver recorded a perfect weekend with a second victory and at the same time capturing the lead of the Championship. In race 1, he was ahead of the other two strong men of the weekend, the Danish driver Lasse Sorensen and Swiss-English Félix Hirsiger.

After a rainy morning, leaving some uncertainty about the track conditions for this last race of the weekend, the Academy students had a perfectly dry track for the start.



Dorian Boccolacci and Lasse Sorensen shared the front row and the second was occupied by the Swiss drivers Paul Hokfelt and Felix Hirsiger. The fastest man in race 2, the Swiss driver David Droux started on the 5th row with Valentin Hasse-Clot at his side. The start was uneventful for the 23 cars composing the field of this race. After a few laps, Dorian Boccolacci, Lasse Sorensen and Felix Hirsiger, placed third on the first lap, started an intense struggle. Lasse Sorensen moved up very quickly right behind Dorian Boccolacci's exhaust, who left no chance for his opponent. The race was interrupted at the start of

the second lap by a remake of race 1 with a tussle at the school corner between Valentin Hasse-Clot and Paul Jr Hokfelt causing a blockage at the curve and consequently the red flag went out. The main victims of this incident were the Championship leader, the Australian Joseph Mawson, Valentin Hasse-Clot, the Russian Denis Bulatov and Paul Hokfelt Jr.

For the second time, the start was called by the race director and Dorian Boccolacci after regaining his position as the pole sitter was again the fastest. Learning the Pau street circuit was successful for the young Frenchman but he was closely

followed by Lasse Sorensen who didn't make it easy for him. Behind this pair Felix Hirsiger led the pack that consisted of David Droux, Valentin Moineault, Erwan Jule, Bryan Elpitiya and Amaury Richard.

The halfway point was marked by a crash for Hugo Sugnot Darniche, requiring the intervention of the safety car to clear the badly damaged car. When its light rail went out, the safety car released a very lively pack because there were only eight laps left and they had to redo all the work.

Dorian Boccolacci made a fluent recovery and traced his path while Bryan Elpitiya

made a mistake at the station corner. The pack followed and seemed to have calmed down from the limit because the attitudes seemed more friendly at the back of the pack. But there was nothing between Dorian Boccolacci and Lasse Sorensen, who were engaged in a great race in front of Felix Hirsiger who had to hold off David Droux and Valentin Moineault who were pressing the Swiss driver hard.

The racing seemed to be calmer at the end of the race, but there was an unexpected passing attempt from Valentin Moineault on David Droux. The outcome of this was fatal for the two drivers who

couldn't restart. Felix Hirsiger took the opportunity to get away and save his third place. Dorian Boccolacci took a brilliant second victory which propelled him to the top of the Championship. Very much at ease, Lasse Sorensen finished second and also scored a lot of points. Felix Hirsiger was third, and also did well in terms of the championship. Dorian Boccolacci: *"I made good starts, which allowed me to maintain the lead throughout the race. I think I have now taken the championship lead. But I won't forget that we are only on the second meeting of the season. I have gone a little ahead but they are not far behind and I'll try to*

*keep going, to win other races and I will count my points at the end of the year."*

**The next meeting of the GT Tour will be at Val de Vienne from July 4th to 6th.**





## AUTO SPORT ACADEMY

By Frédérique Billet / © Photo KSP - Guillaume Veuve

## BOCCOLACCI TAKES THE LEAD IN PAU

On his second single-seater meeting in the streets of Pau, Dorian Boccolacci left his mark by climbing twice on the highest step of the podium and taking the lead in the French F4 Championship overall classification. The competition will stop for a few weeks before the Val de Vienne meeting in early July, but the Lotus F1 Junior Team driver has already taken command despite the difficult conditions of this urban circuit in the South West of France.

The Pau race is a very tough one and no mistake is allowed; its circuit consists of the city centre streets, with no runaway, and it is often compared to Monaco's. As in the Principality of Monaco, overtaking is very difficult. Another thing these two circuits have in common is the fact that it is not possible to explore the track before the free session. A victory in Pau, just as in Monaco or Macao, is a success more important than the others in a list of achievements.

Dorian arrived in the Béarnaise city with just one previous experience with single-seater competitions, in Le Mans, where he conquered his first podium. He followed closely the suggestions of more experienced drivers and was very cautious when he explored the circuit

during free session. «I focussed on learning the circuit. I wanted to drive as many laps as possible», Dorian explained. «But when I saw my position compared to that of the others, 7th at 9 tenths off the fastest driver, I said to myself that I needed to increase the pace a bit!»

No sooner said than done, Dorian increased his speed during the qualifying session despite a few disruptions on the track and set his fastest time - 1'19''629 - as well as his second best time with only a few laps to go; thanks to these two performances, he took pole at the start of Race 3 and of Race 1. A big step closer to victory!

What came next? It was important to make a good start or rather several good starts, because these races are often stopped with the red flag. He accomplished his mission at the start of Race 1, and then again when the race was re-started, after a chain crash behind him. Each time, Dorian overtook Lasse Sorensen, his main rival. Then he had to manage the threat posed by the Danish driver in the early laps to prevent him from overtaking. Dorian's times improved as the race went by and he concluded in the lead with the fastest lap.



The reverse-grid system was applied to the first 10 drivers in Race 2 and Dorian started 10th on the grid. He did not try too hard to overtake the fast drivers who preceded him; he decided wisely to avoid damaging his car and crossed the finish line 9th.

On Sunday, Race 3 looked pretty much like Race 1. Dorian made a good start, and another one when the race started again after a red flag; he was ideally placed when the safety car left the track, he controlled Sorensen in the early laps and then took a slight lead over him just near the finish line.

«I much enjoyed driving in the streets of Pau. It was very exciting! It is very gratifying to win two races on the same weekend, especially because now I am the leader of the French Championship! I wish to thank all those who have helped me in preparing special meeting and who will recognise themselves!»

DORIAN BOCCOLACCI







## AUTO SPORT ACADEMY

By Frédérique Billet / © Photo KSP - Guillaume Veuve

BRYAN ELPITIYA

# ELPITIYA HAS A DIFFICULT WEEKEND ON THE STREETS OF PAU

Arriving in fifth position in the French F4 Championship after his victory in race 2 at Le Mans, Bryan Elpitiya had done well from his good score in the second race of the season. But the Béarnais meeting proved more complicated than expected for the young rookie.

Qualified in the top 10 on a difficult and tricky track, Bryan saw his car badly damaged in race 1 after a monster crash that blocked the track. He managed to reach the pits but could not restart because of a destroyed front end. Even worse, he now needed to start from back of the grid in race 2.

Despite this Bryan gave his best. While overtaking is almost impossible on this street circuit, the Parisian driver did not hesitate to attack several times. Making the best recovery, he managed to gain a whopping seven places before his wing broke in a contact with Joseph Mawson on lap 13. Bryan lost three places in the incident, but managed to recover in the last three laps and finally took 14th.

Bryan made an impeccable start in race 3 on Sunday and was in sixth position. But it was definitely not his weekend: for three laps behind the safety car, he could not keep his tyres warm enough, through lack of experience, and made a mistake at the first corner after the restart.

*"It was a very hard meeting," Bryan confided afterwards. "Sunday night I was obviously disappointed. Fortunately, I have not really dropped in the Championship where I am in 8th position. I am determined to respond at the next race at Val de Vienne. It is important to score a lot of points and not to let the leaders escape before Magny-Cours, the turning point of the season."*





world series  
by RENAULT



FR 2.0

Info & © Photo Renault Sport

## ALEXANDER ALBON : “I HAVE TO DO WELL FOR MY FUTURE”

In his third season in the Eurocup Formula Renault 2.0, Alexander Albon is the most experienced of the three Lotus F1 Junior Team drivers in the category. Among the quickest during the collective tests as well as the Motorland Aragón meeting, the Thai, born in London is in the final stage of his reconstruction after two difficult years in single-seaters.

Following a standout career in karting that was capped off with a win in the KF3 World Cup and the title in the 2010 KF3 European Championship, then a runner-up finish in the 2011 Karting World Cup, Alexander Albon made his single-seater debut during the 2012 season.

With the backing of the Red Bull Junior Team, the Thai honed his skills in a one year stint with the Epic Racing team. While the results were disappointing, his campaign in the ALPS championship was encouraging. As the lone driver in the squad, he finished in the points six times.



*“Going from karting to single-seaters is always a massive step”, admits Alex Albon. “My first year was definitely the worst I ever had in terms of racing. I was by myself in the team. Not having an experienced team mate meant I didn’t know where I was wrong or where I needed to improve.”*

*“Between the downforce, speed and racing schedule, there was a lot to learn in a short period of time ! If I could go back in time, I would have started my training six months to a full year earlier before the start of the collective test ! A lot of rookies now do this and it definitely works as there are a lot of fast newcomers in Formula Renault.”*

After losing Red Bull’s support at the end of 2012, Alexander Albon spent the 2013 season in rebuilding mode after a stressful winter.

*“It was an important phase. At the end of the year, I was very down. I felt dropped so late, it was a worrying time for me. Fortunately I was surrounded by people who really supported me and I am very thankful for that. They were the ones who guided me and helped me to rebuild myself.”*

Recruited by the Lotus F1 Junior Team, Alexander Albon joined the KTR team and demonstrated the progress he had made in taking the pole at the Red Bull Ring. A jump start cost him his chances for the win, but he stepped onto the podium for the first time in a NEC event, at the Most Autodrom.

*“Being with Lotus, there are a lot of benefits. They help us find the sponsors to race, which is essential. They also offer media support and advice, fitness programmes and camps, as*

*well as on and off track guidance. We are given the best chance and the best conditions to perform at the top !”*

*“2013 started off a bit slow but ended up well towards the end. The main goal was to score points and we got there by mid-season. From then on, we were getting more competitive, the highlight being Red Bull Ring. Only a jump start got in the way of me winning for the first time, but what was essential was we were always progressing right through to winter testing where we were very quick”*

Choosing to stay with KTR for 2014, Alexander Albon is aware of the weight on his shoulders. Among the leaders throughout the pre-season, the native of London seems to have taken his racing to the next level as was shown during the first meeting of the year at Motorland Aragón.

“I chose to stay with KTR because I believe I can win the championship with them. We understand each other very well and we definitely have the pace to do it. We have made a big leap forward compared to last year.

*“The key will be consistency,” continues the Lotus protégé. “We also have to ensure to go into every race as prepared as possible. The Eurocup Formula Renault 2.0 is so close that it’s tenths separating the top half of the field to the bottom. I have to do well for my future, but I want to do well for myself. The main thing is to enjoy it and do the best you can and then see from there !”*



# ALEXANDER ALBON

## BORN

23 March 1996 in London (Great-Britain)

## HEIGHT/ WEIGHT

1.85m / 67kg

## PALMARÈS

2006-2011 : Karting

2009 : Super 1 National KF3 Championship (Champion)

2010 : KF3 World Cup (Champion), KF3 European Championship (Champion)

2011 : KF1 World Championship (Champion)

2012 : Eurocup Formula Renault 2.0 (38th), Formula Renault 2.0 ALPS (16th)

2013 : Eurocup Formula Renault 2.0 (16th)

2014 : Eurocup Formula Renault 2.0



## ALEX BARON INDY LIGHTS (LONG BEACH 2014) REPORTAGE L'EQUIPE TV



## EUROPEAN CHAMPIONSHIP 2014 LA CONCA, FINALE KF



## SUPERKART A HOCKENHEIM - HENRICK LIJA



## EUROPEAN CHAMPIONSHIP 2014 LA CONCA, FINALE KFJ

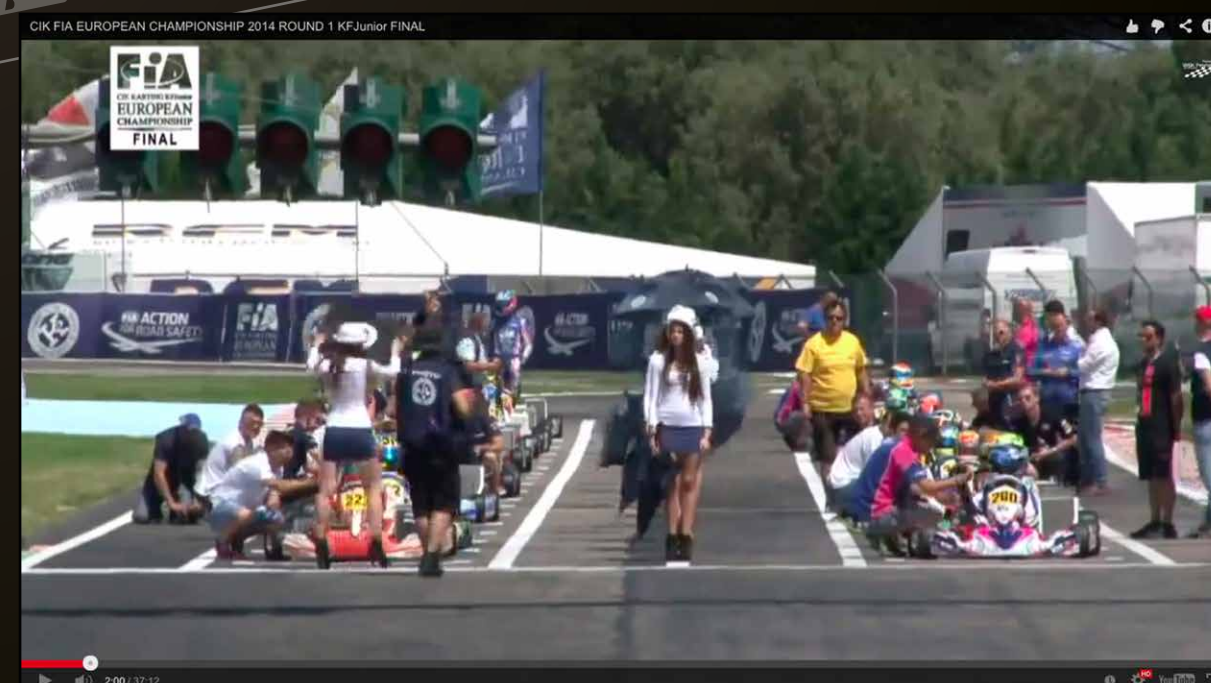





POUR TOUS **LES PASSIONNÉS** DU SPORT

# KARTING

**WWW.ACTION-WEBSTORE.FR**

Un réseau avec **+ 60 distributeurs**

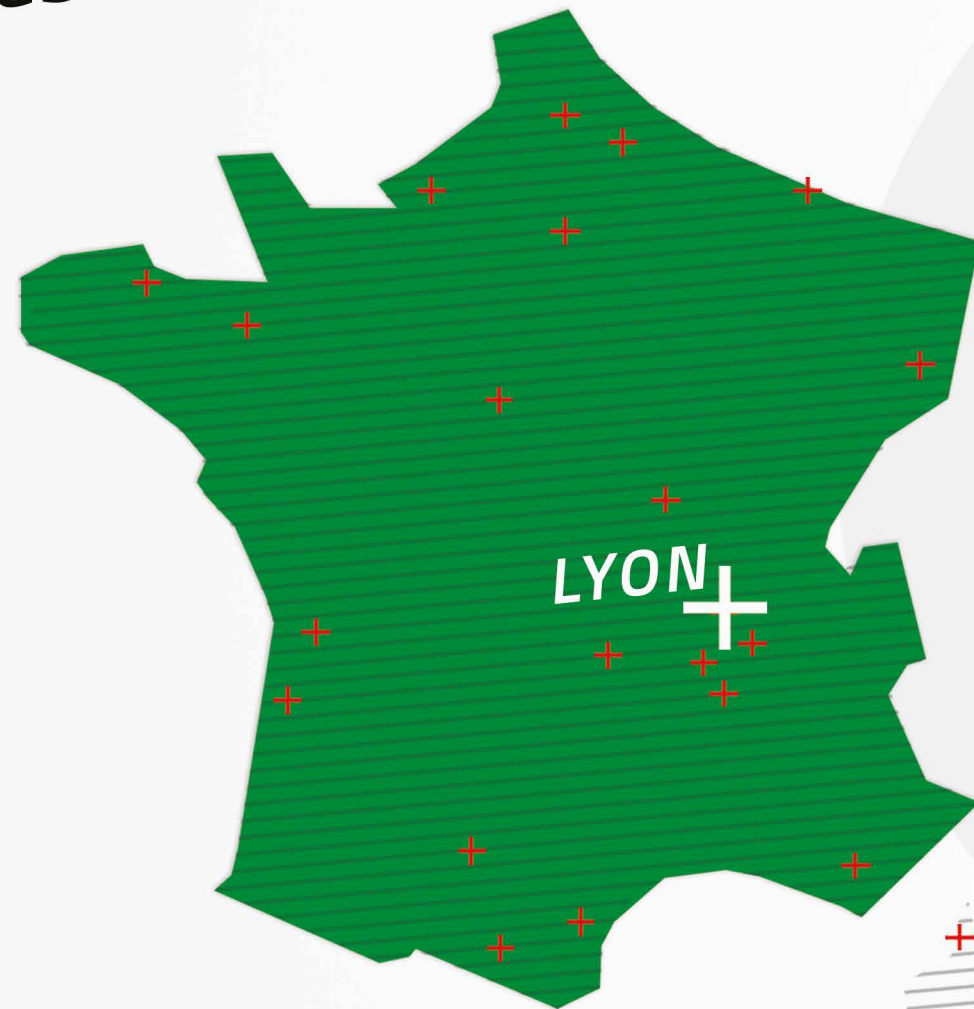

LYON

**Le plus grand magasin et le meilleur service de France**



**Catalogue & Site de vente en ligne**  
+ De 4400 références en stock

**WWW.ACTIONKARTING.FR**

**UN SERVICE COMPÉTITION POUR TOUS!**



N° Indigo 0 820 825 136

0,118 € TTC / MN





# CIK-FIA INTERNATIONAL PHOTO CONTEST "BEST PHOTOGRAPH OF THE YEAR"

Best photograph of the year 2007, 2008, 2011, 2012 & 2013



Join us



PHOTO AGENCY DEDICATED TO KARTING



WWW.KSP-PHOTO-AGENCY.COM